

# The God Particle

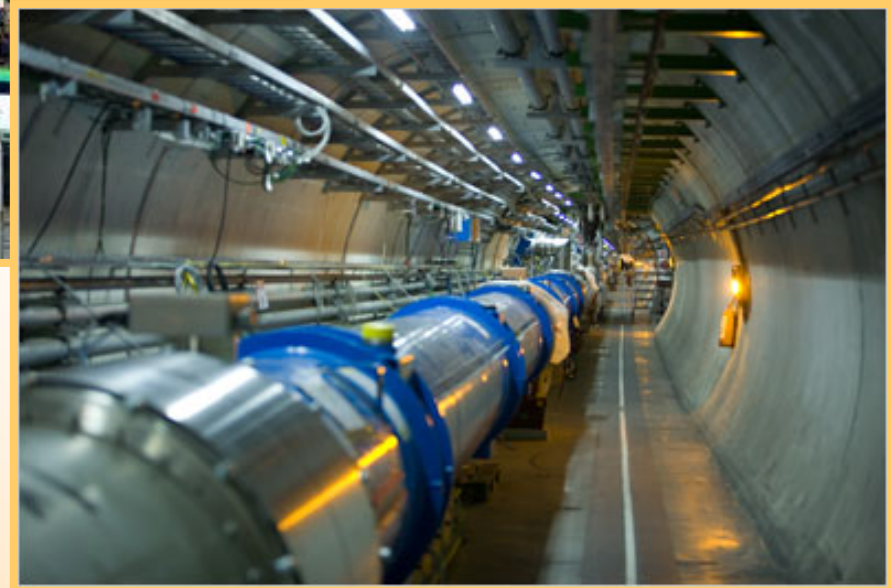

# The Large Hadron Collider

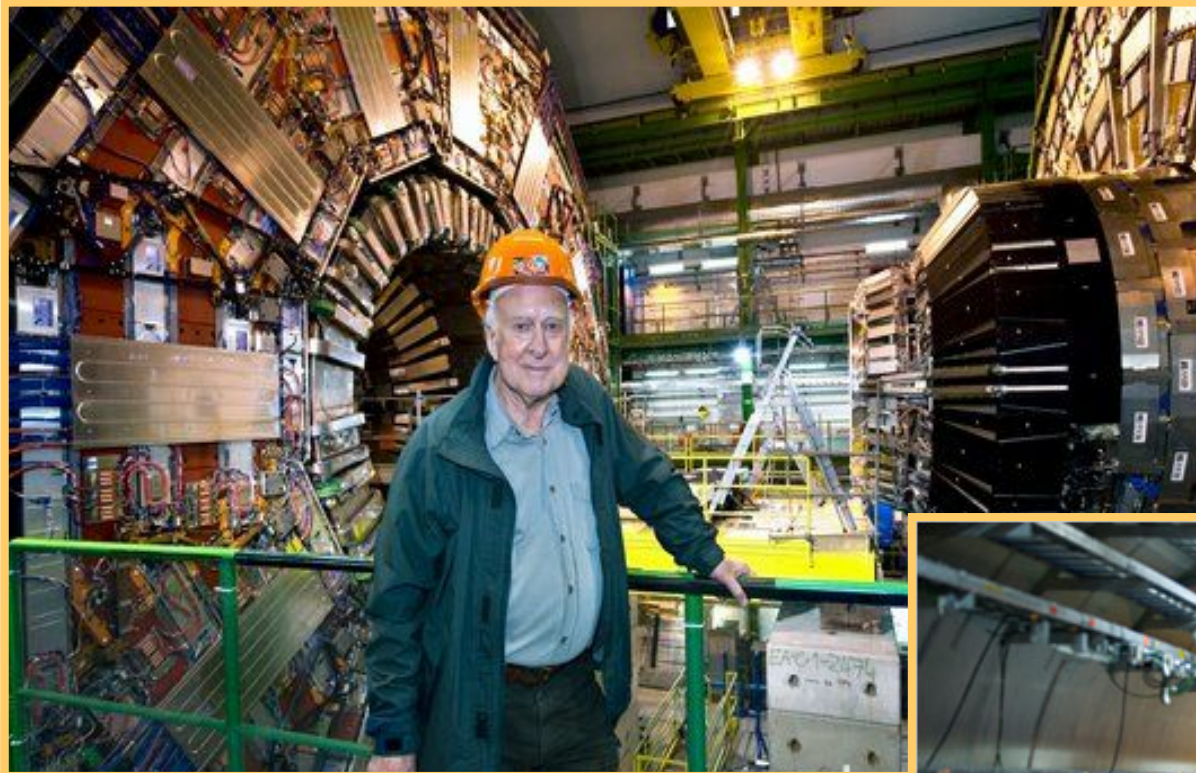

# Leon Lederman

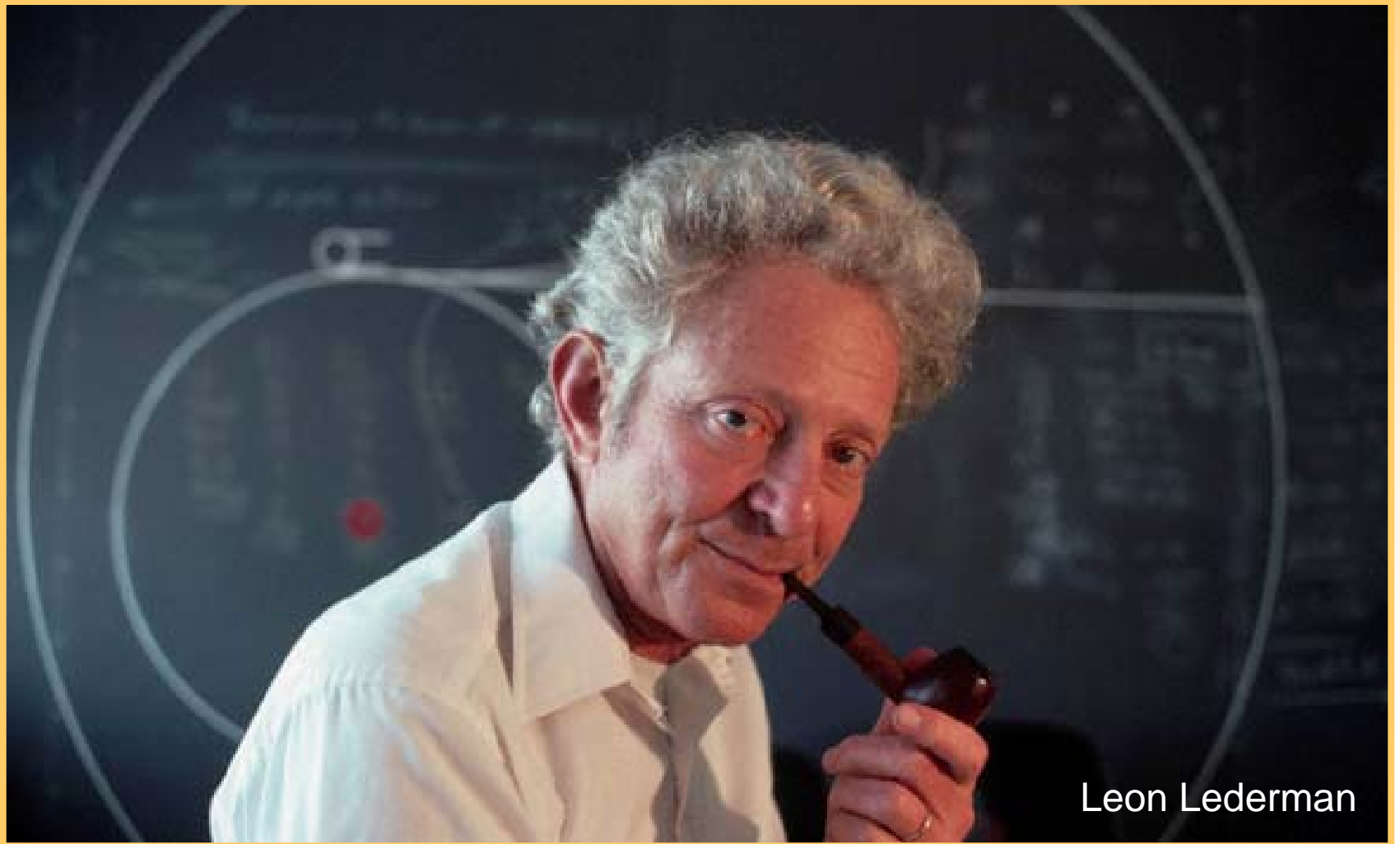

Leon Lederman

# Peter Higgs



**Peter Higgs**

# Modern View of the Atom

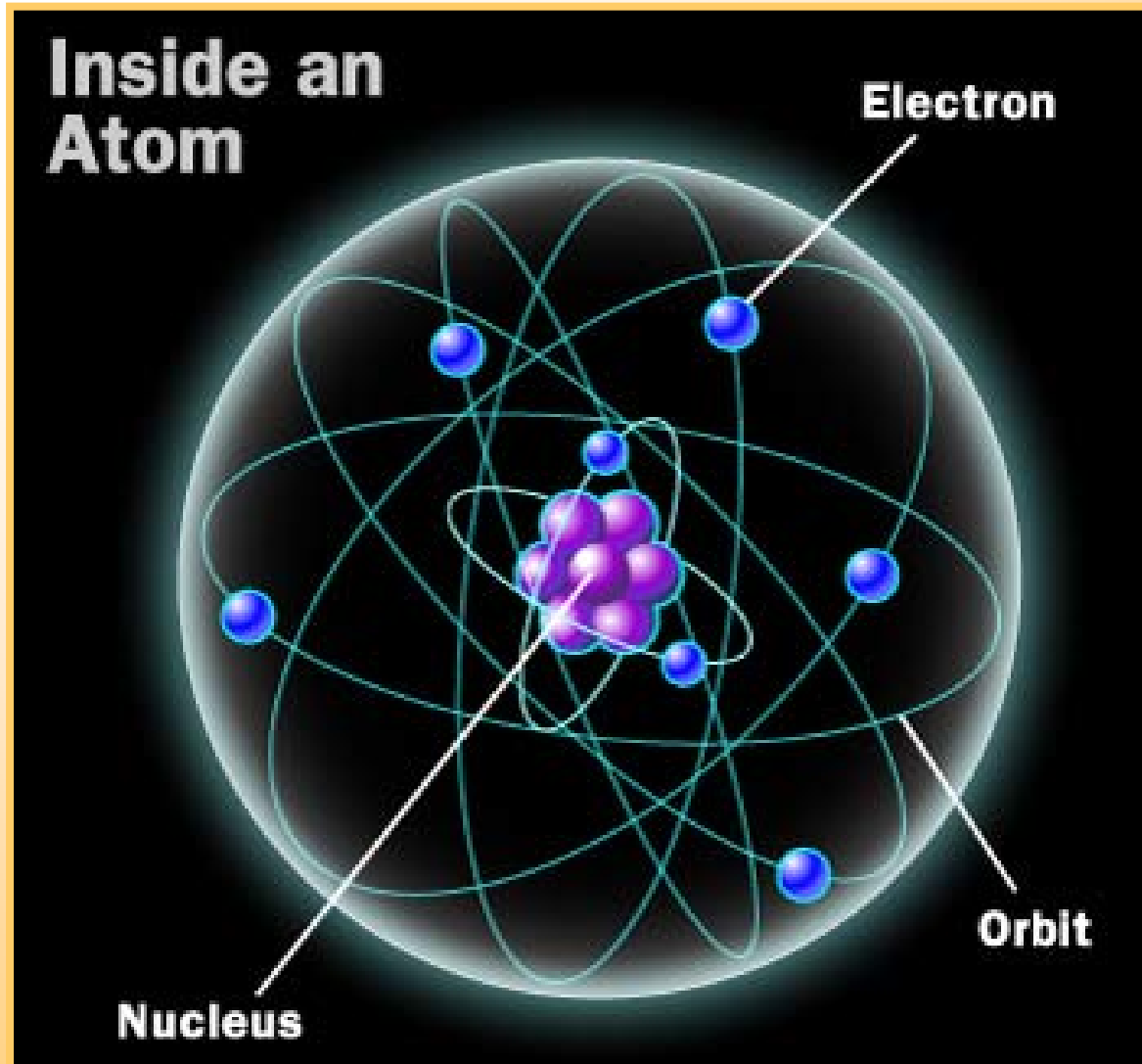

# John Dalton

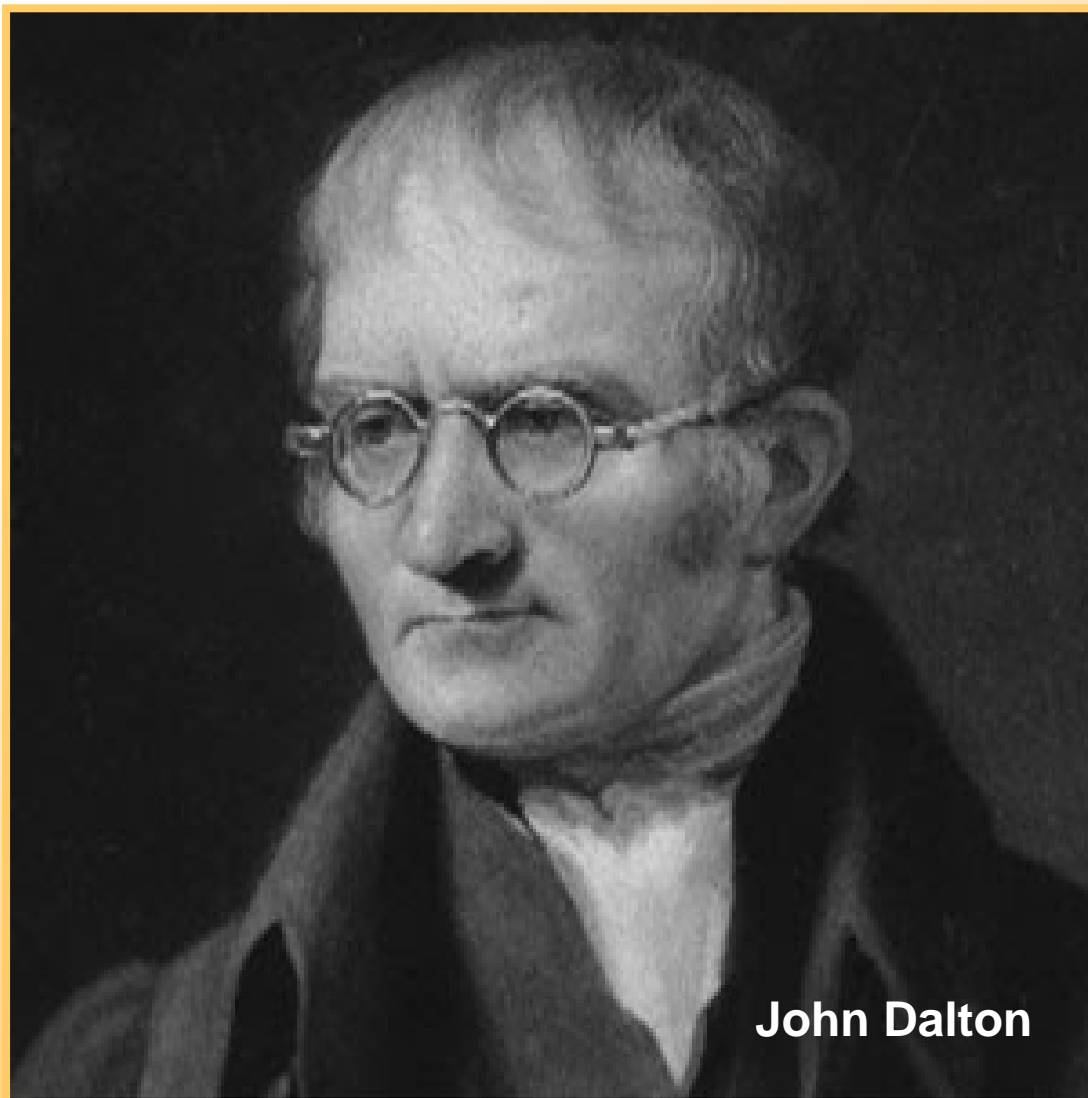

# Water Molecule

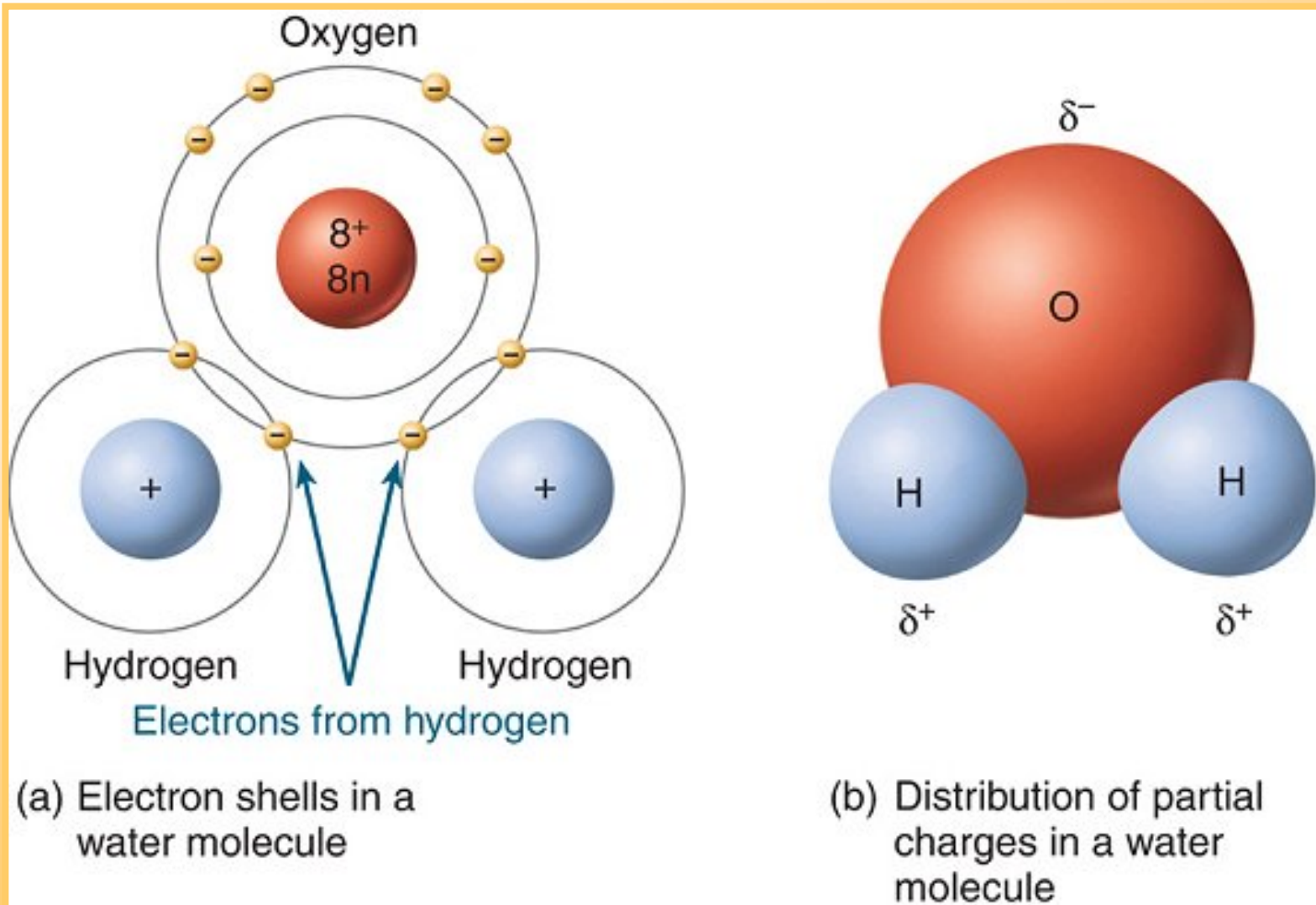

# Table of the Elements

**PERIODIC TABLE OF THE ELEMENTS**

<http://www.kf-split.hr/periodni/en/>

PERIOD	GROUP	1	2	3	4	5	6	7	8	9	10	11	12	13	14	15	16	17	18		
		IA	IIA	LANTHANIDE										IIIA	IVA	VA	VIA	VIIA	VIIIA		
1		1.0079 <b>H</b> HYDROGEN												10.811 <b>B</b> BORON	12.011 <b>C</b> CARBON	14.007 <b>N</b> NITROGEN	15.999 <b>O</b> OXYGEN	18.998 <b>F</b> FLUORINE	4.0026 <b>He</b> HELIUM		
2		6.941 <b>Li</b> LITHIUM	9.0122 <b>Be</b> BERYLLIUM											20.180 <b>Ne</b> NEON							
3		22.990 <b>Na</b> SODIUM	24.305 <b>Mg</b> MAGNESIUM											26.982 <b>Al</b> ALUMINIUM	28.086 <b>Si</b> SILICON	30.974 <b>P</b> PHOSPHORUS	32.065 <b>S</b> SULPHUR	35.453 <b>Cl</b> CHLORINE	39.948 <b>Ar</b> ARGON		
4		39.098 <b>K</b> POTASSIUM	40.078 <b>Ca</b> CALCIUM	44.956 <b>Sc</b> SCANDIUM	47.867 <b>Ti</b> TITANIUM	50.942 <b>V</b> VANADIUM	51.996 <b>Cr</b> CHROMIUM	54.938 <b>Mn</b> MANGANESE	58.933 <b>Fe</b> IRON	58.693 <b>Co</b> COBALT	63.546 <b>Ni</b> NICKEL	65.39 <b>Cu</b> COPPER	65.39 <b>Zn</b> ZINC	69.723 <b>Ga</b> GALLIUM	72.64 <b>Ge</b> GERMANIUM	74.922 <b>As</b> ARSENIC	78.96 <b>Se</b> SELENIUM	79.904 <b>Br</b> BROMINE	83.80 <b>Kr</b> KRYPTON		
5		85.468 <b>Rb</b> RUBIDIUM	87.62 <b>Sr</b> STRONTIUM	88.906 <b>Y</b> YTTRIUM	91.224 <b>Zr</b> ZIRCONIUM	92.906 <b>Nb</b> NIOBIUM	95.94 <b>Mo</b> MOLYBDENUM	(98) <b>Tc</b> TECHNETIUM	101.07 <b>Ru</b> RUTHENIUM	102.91 <b>Rh</b> RHODIUM	106.42 <b>Pd</b> PALLADIUM	107.87 <b>Ag</b> SILVER	112.41 <b>Cd</b> CADMIUM	114.82 <b>In</b> INDIUM	118.71 <b>Sn</b> TIN	121.76 <b>Sb</b> ANTIMONY	127.60 <b>Te</b> TELLURIUM	126.90 <b>I</b> IODINE	131.29 <b>Xe</b> XENON		
6		132.91 <b>Cs</b> CAESIUM	137.33 <b>Ba</b> BARIUM	57-71 <b>La-Lu</b> Lanthanide	178.49 <b>Hf</b> HAFNIUM	180.95 <b>Ta</b> TANTALUM	183.84 <b>W</b> TUNGSTEN	186.21 <b>Re</b> RHENIUM	190.23 <b>Os</b> OSMIUM	192.22 <b>Ir</b> IRIDIUM	195.08 <b>Pt</b> PLATINUM	196.97 <b>Au</b> GOLD	200.59 <b>Hg</b> MERCURY	204.38 <b>Tl</b> THALLIUM	207.2 <b>Pb</b> LEAD	208.98 <b>Bi</b> BISMUTH	(209) <b>Po</b> POLONIUM	(210) <b>At</b> ASTATINE	(222) <b>Rn</b> RADON		
7		(223) <b>Fr</b> FRANCIUM	(226) <b>Ra</b> RADIUM	89-103 <b>Ac-Lr</b> Actinide	(261) <b>Rf</b> RUTHERFORDIUM	(262) <b>Db</b> DUBNIUM	(266) <b>Sg</b> SEABORGIUM	(264) <b>Bh</b> BOHRIUM	(277) <b>Hs</b> HASSIUM	(288) <b>Mt</b> MEITNERIUM	(281) <b>Uun</b> UNUNNIUM	(272) <b>Uuu</b> UNUNUNIUM	(285) <b>Uub</b> UNUNBIUM		(289) <b>Uuq</b> UNUNQUADIUM						

RELATIVE ATOMIC MASS (A)

GROUP IUPAC

GROUP CAS

ATOMIC NUMBER

SYMBOL

ELEMENT NAME

Metal

Semimetal

Nonmetal

1 Alkali metal

2 Alkaline earth metal

Transition metals

Lanthanide

Actinide

16 Chalcogens element

17 Halogens element

18 Noble gas

STANDARD STATE (25 °C; 101 kPa)

Ne - gas

Fe - solid

Ga - liquid

Tc - synthetic

**LANTHANIDE**

57 138.91 <b>La</b> LANTHANUM	58 140.12 <b>Ce</b> CERIUM	59 140.91 <b>Pr</b> PRASEODYMIUM	60 144.24 <b>Nd</b> NEODYMIUM	61 (145) <b>Pm</b> PROMETHIUM	62 150.36 <b>Sm</b> SAMARIUM	63 151.96 <b>Eu</b> EUROPIUM	64 157.25 <b>Gd</b> GADOLINIUM	65 158.93 <b>Tb</b> TERBIUM	66 162.50 <b>Dy</b> DYSPROSIUM	67 164.93 <b>Ho</b> HOLMIUM	68 167.26 <b>Er</b> ERBIUM	69 168.93 <b>Tm</b> THULIUM	70 173.04 <b>Yb</b> YTTERIUM	71 174.97 <b>Lu</b> LUTETIUM
-------------------------------------	----------------------------------	--	-------------------------------------	-------------------------------------	------------------------------------	------------------------------------	--------------------------------------	-----------------------------------	--------------------------------------	-----------------------------------	----------------------------------	-----------------------------------	------------------------------------	------------------------------------

Copyright © 1998-2003 EniG. (eni@kf-split.hr)

(1) Pure Appl. Chem., 73, No. 4, 667-683 (2001)  
Relative atomic mass is shown with five significant figures. For elements having no stable nuclides, the value enclosed in brackets indicates the mass number of the longest-lived isotope of the element.

However three such elements (Th, Pa, and U) do have a characteristic terrestrial isotopic composition, and for these an atomic weight is tabulated.

**ACTINIDE**

89 (227) <b>Ac</b> ACTINIUM	90 232.04 <b>Th</b> THORIUM	91 231.04 <b>Pa</b> PROTACTINIUM	92 238.03 <b>U</b> URANIUM	93 (237) <b>Np</b> NEPTUNIUM	94 (244) <b>Pu</b> PLUTONIUM	95 (243) <b>Am</b> AMERICIUM	96 (247) <b>Cm</b> CURIUM	97 (247) <b>Bk</b> BERKELIUM	98 (251) <b>Cf</b> CALIFORNIUM	99 (252) <b>Es</b> EINSTEINIUM	100 (257) <b>Fm</b> FERMIUM	101 (258) <b>Md</b> MENDELEVIUM	102 (259) <b>No</b> NOBELIUM	103 (262) <b>Lr</b> LAWRENCIUM
-----------------------------------	-----------------------------------	--	----------------------------------	------------------------------------	------------------------------------	------------------------------------	---------------------------------	------------------------------------	--------------------------------------	--------------------------------------	-----------------------------------	---------------------------------------	------------------------------------	--------------------------------------

Editor: Aditya Vardhan (advir@netlinx.com)

# Johann Loschmidt

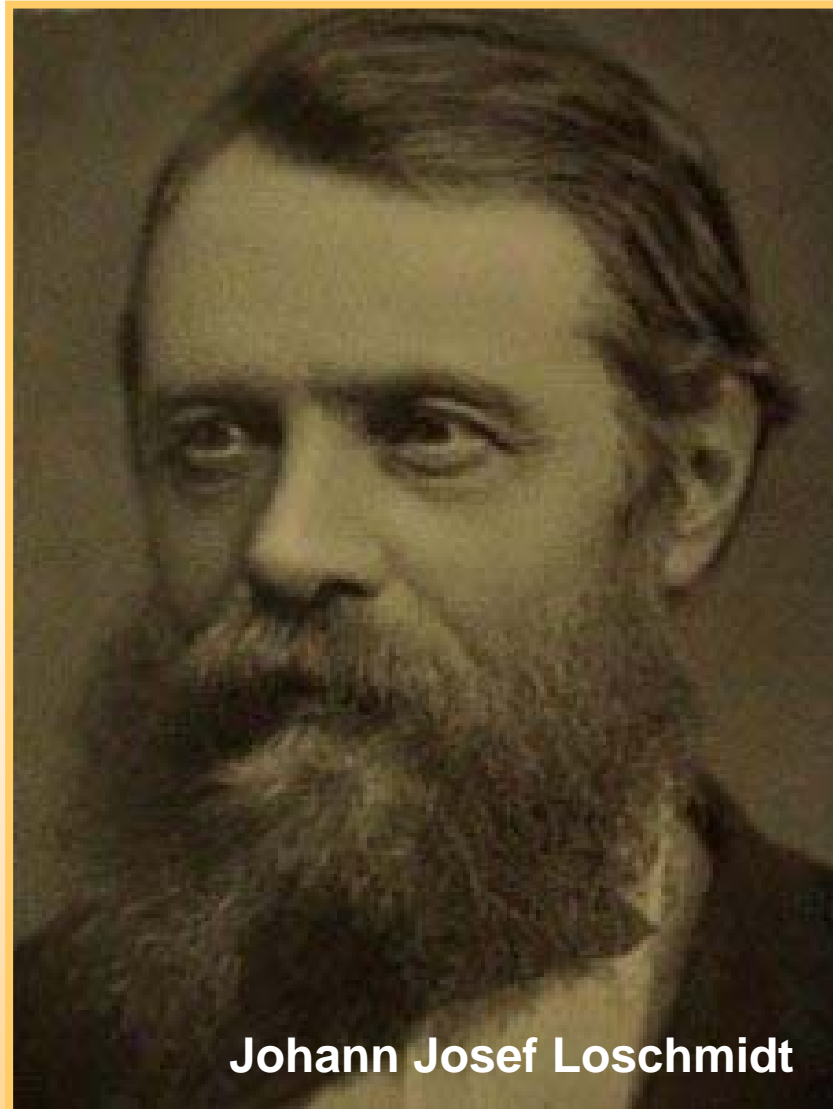

Johann Josef Loschmidt

# Robert Brown



Robert Brown

# Brownian Motion

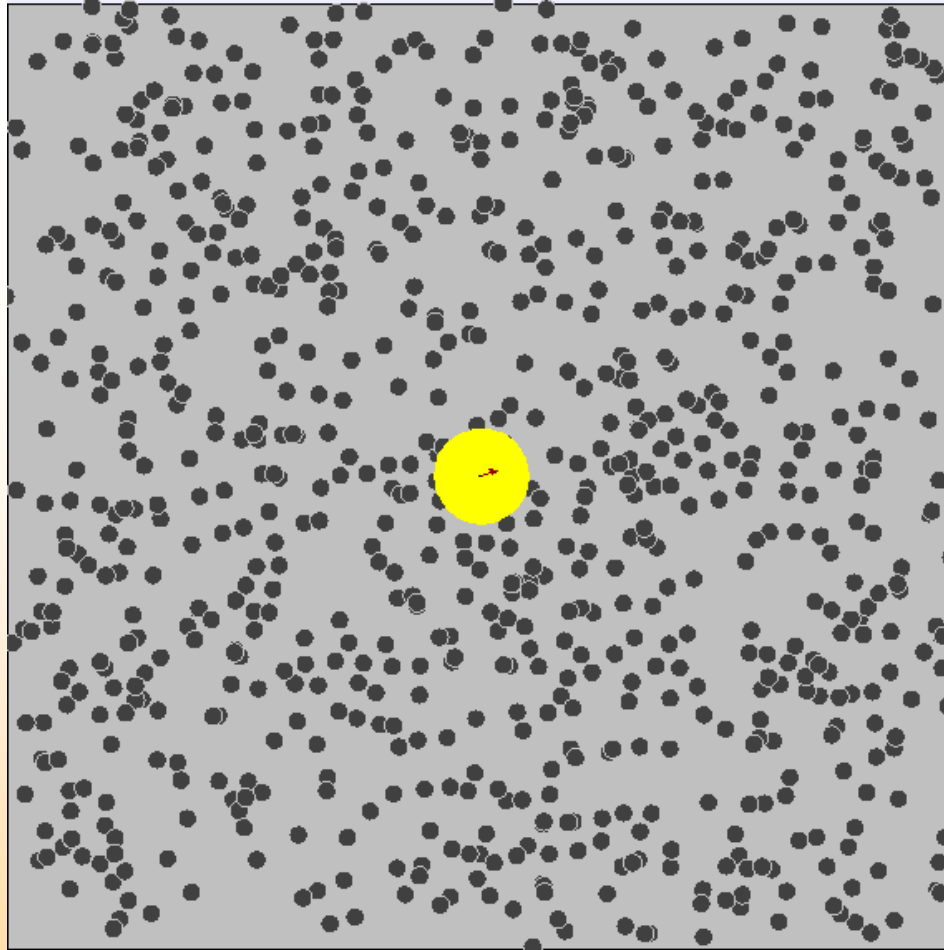

# Albert Einstein

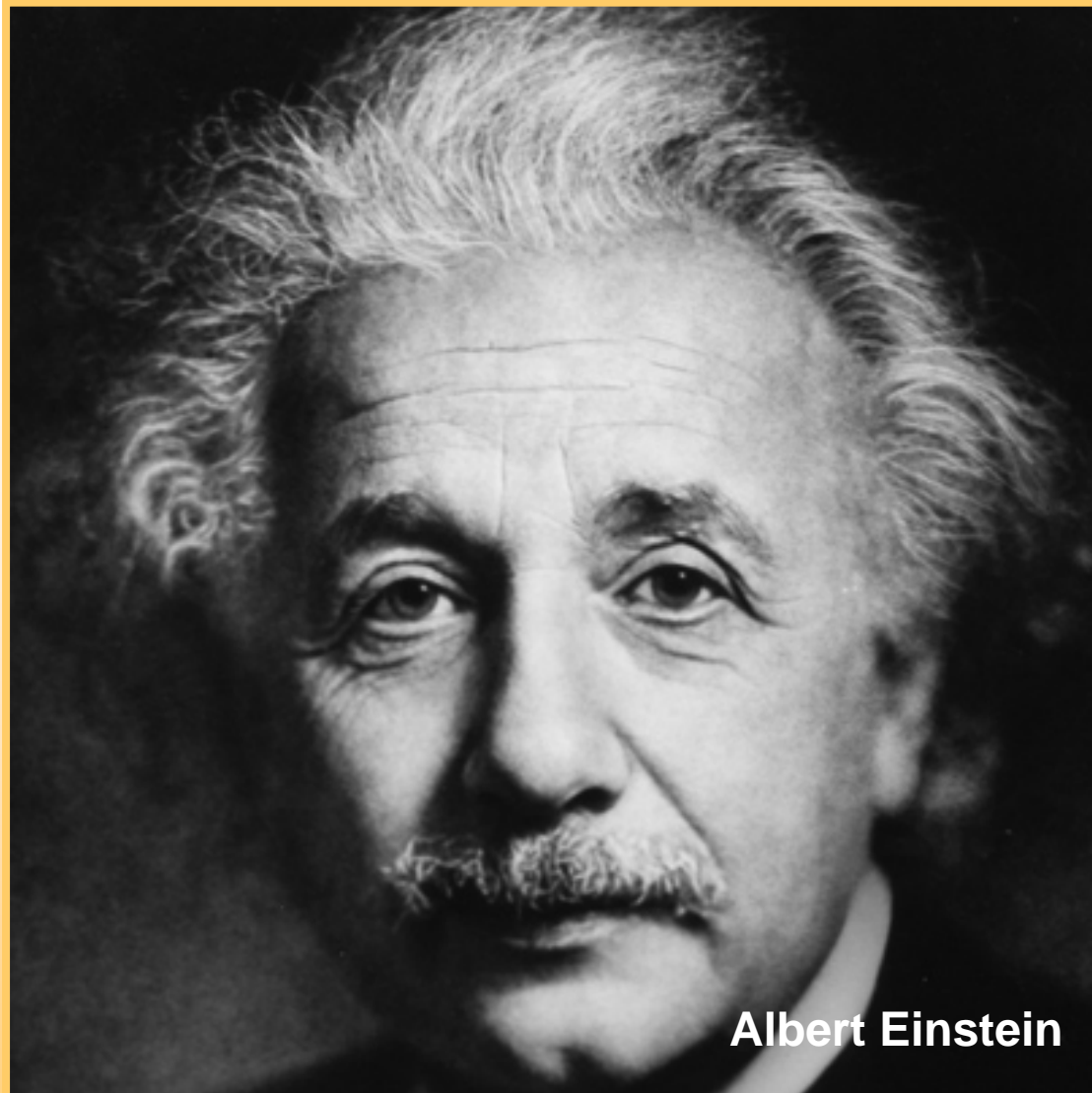

Albert Einstein

# J J Thomson



# Early Cathode Ray Tube

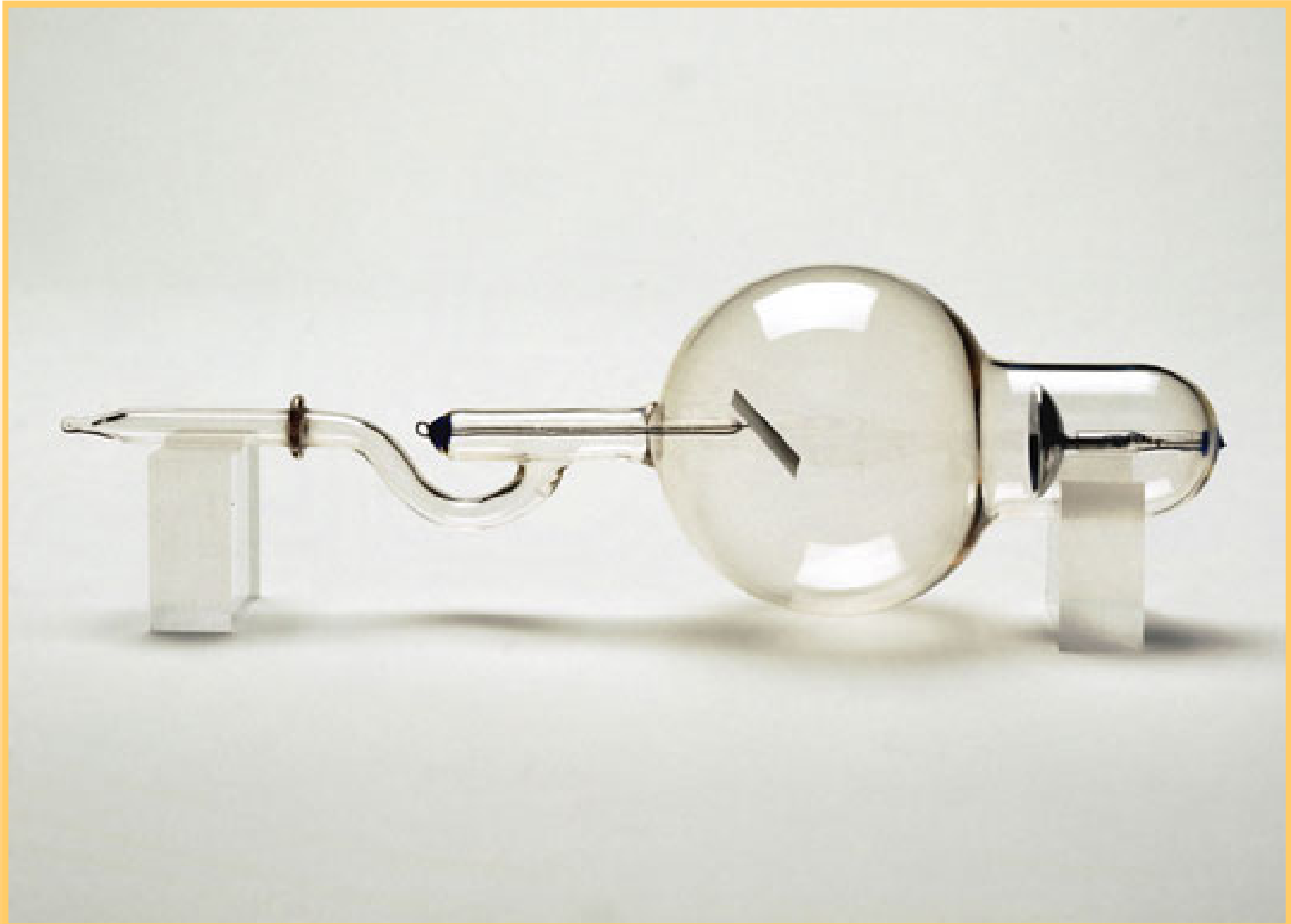

# 'Plum Pudding' Atom



Plum Pudding Model

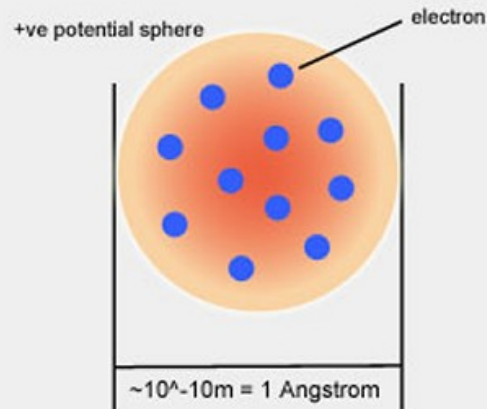

Nuclear Model

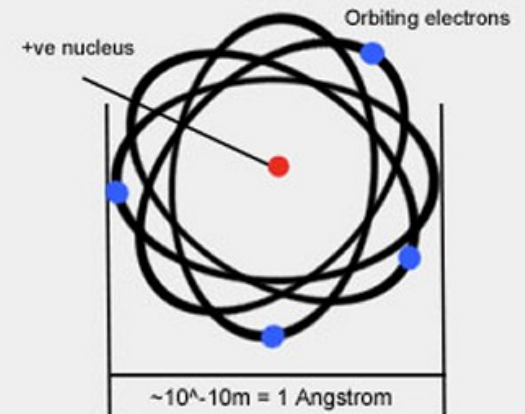

# Niels Bohr

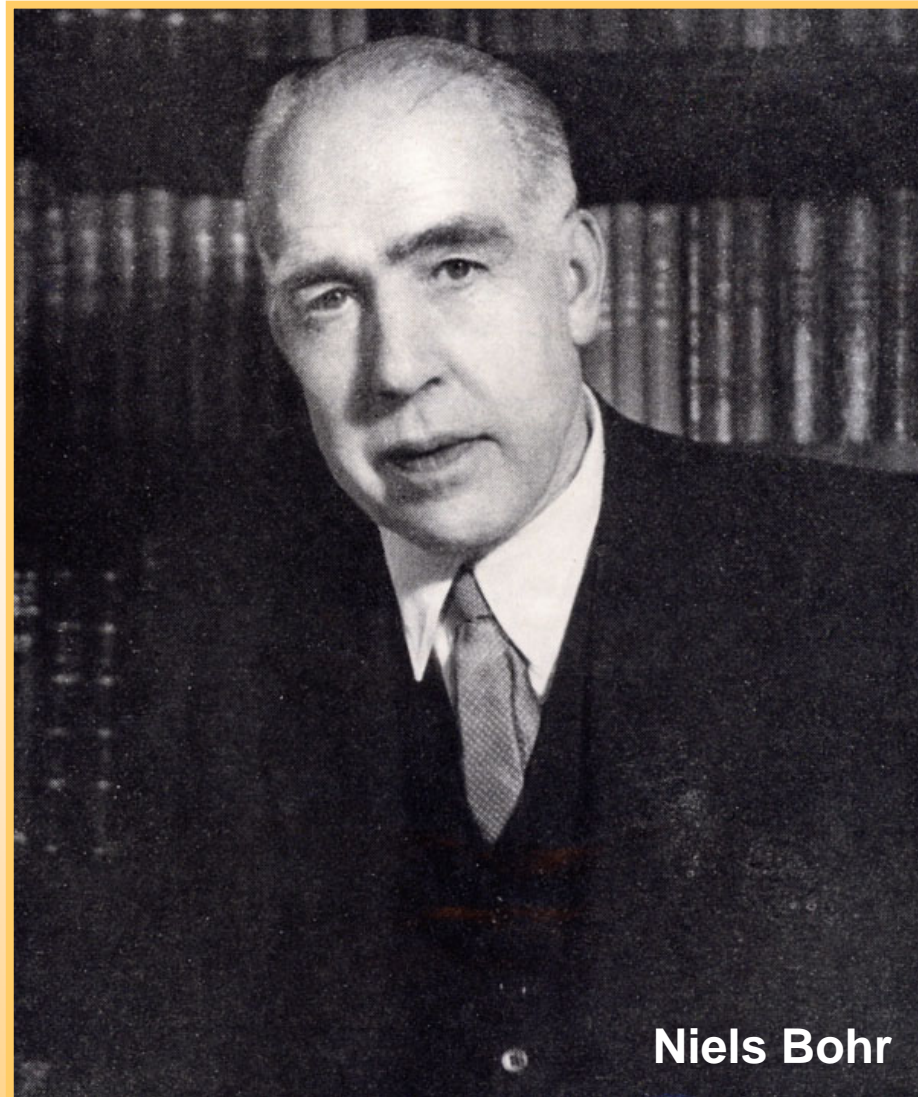

Niels Bohr

# Englert and Brout



Englert and Brout

# Ernest Rutherford

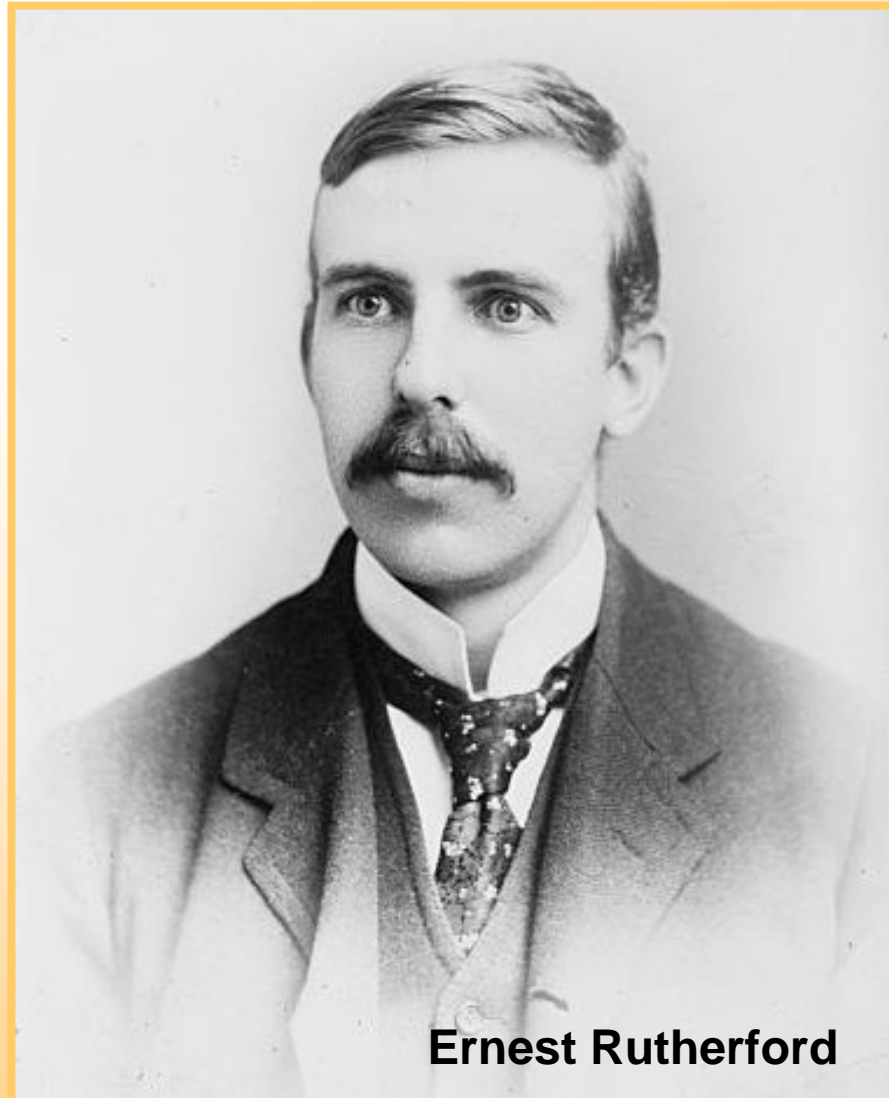

**Ernest Rutherford**

# Alpha Particle

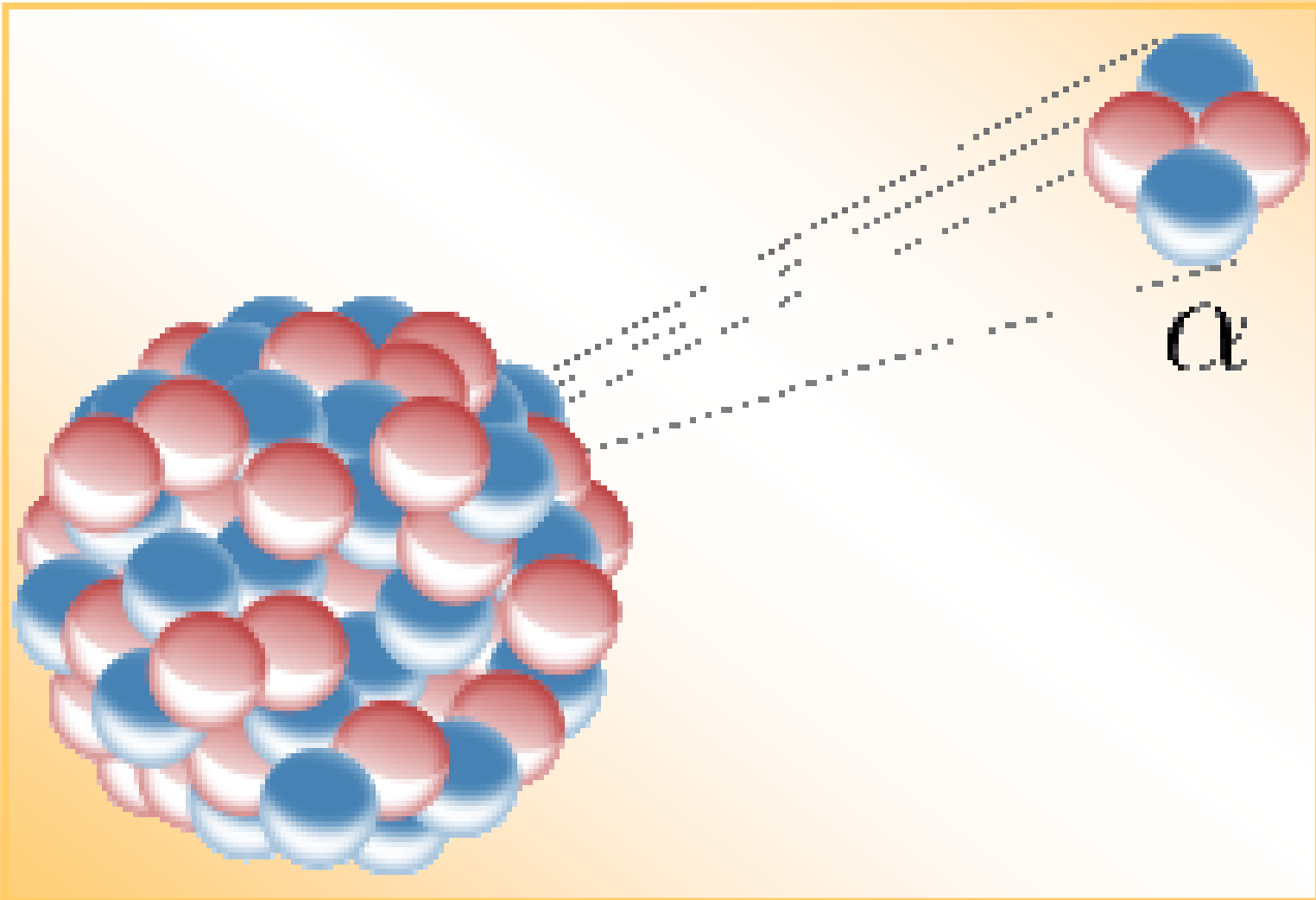

# Rutherford's Nuclear Atom

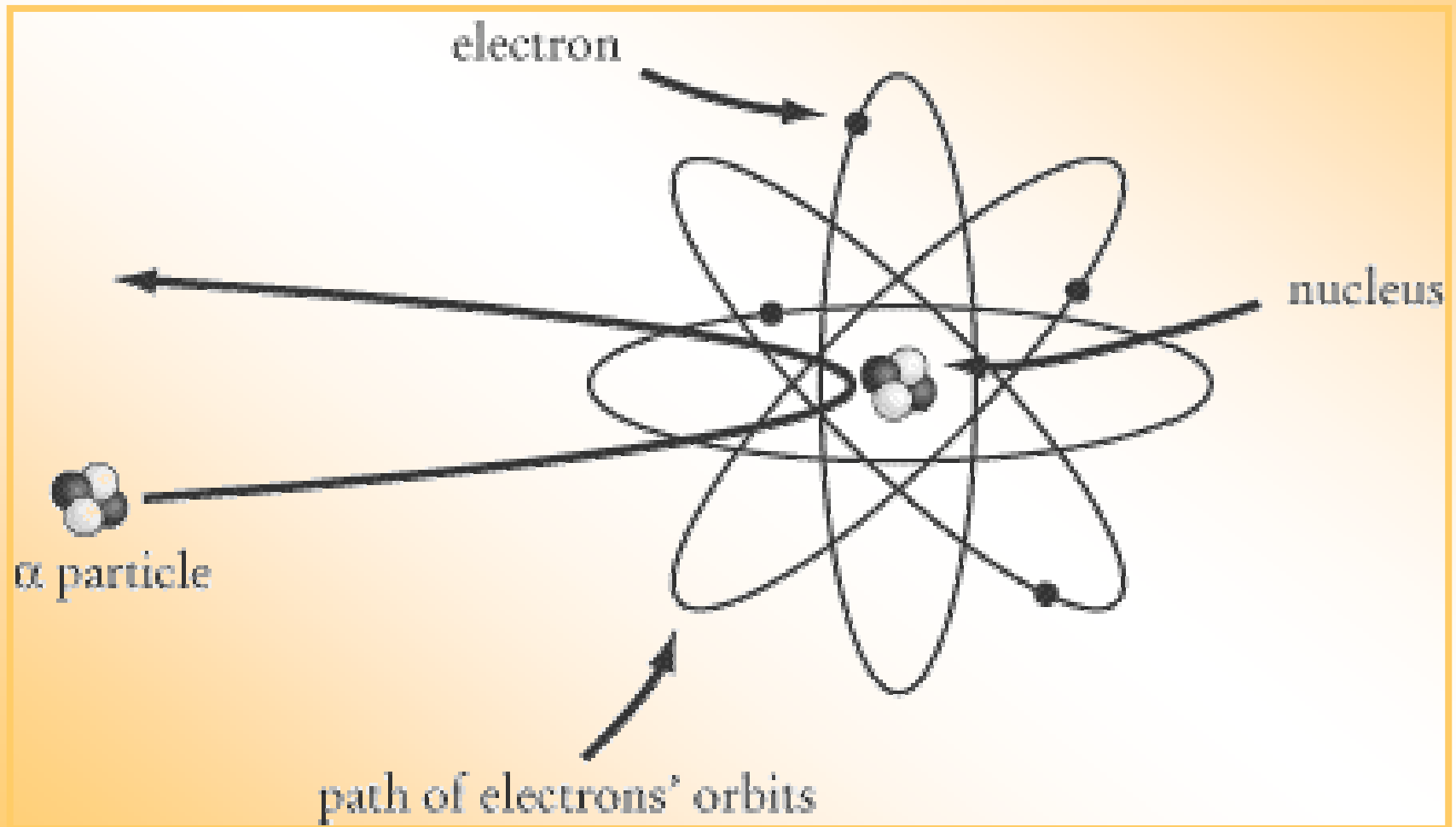

# Frederick Soddy



Frederick Soddy

# Max Planck

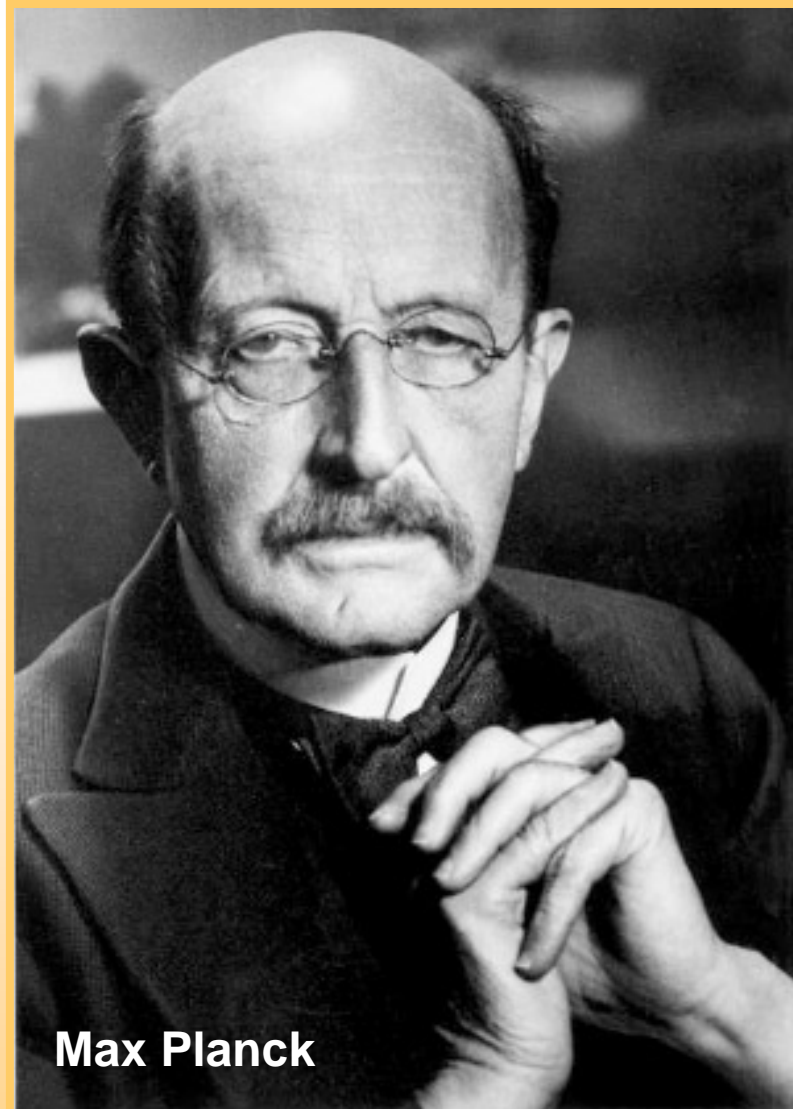

Max Planck

# Electron Orbitals

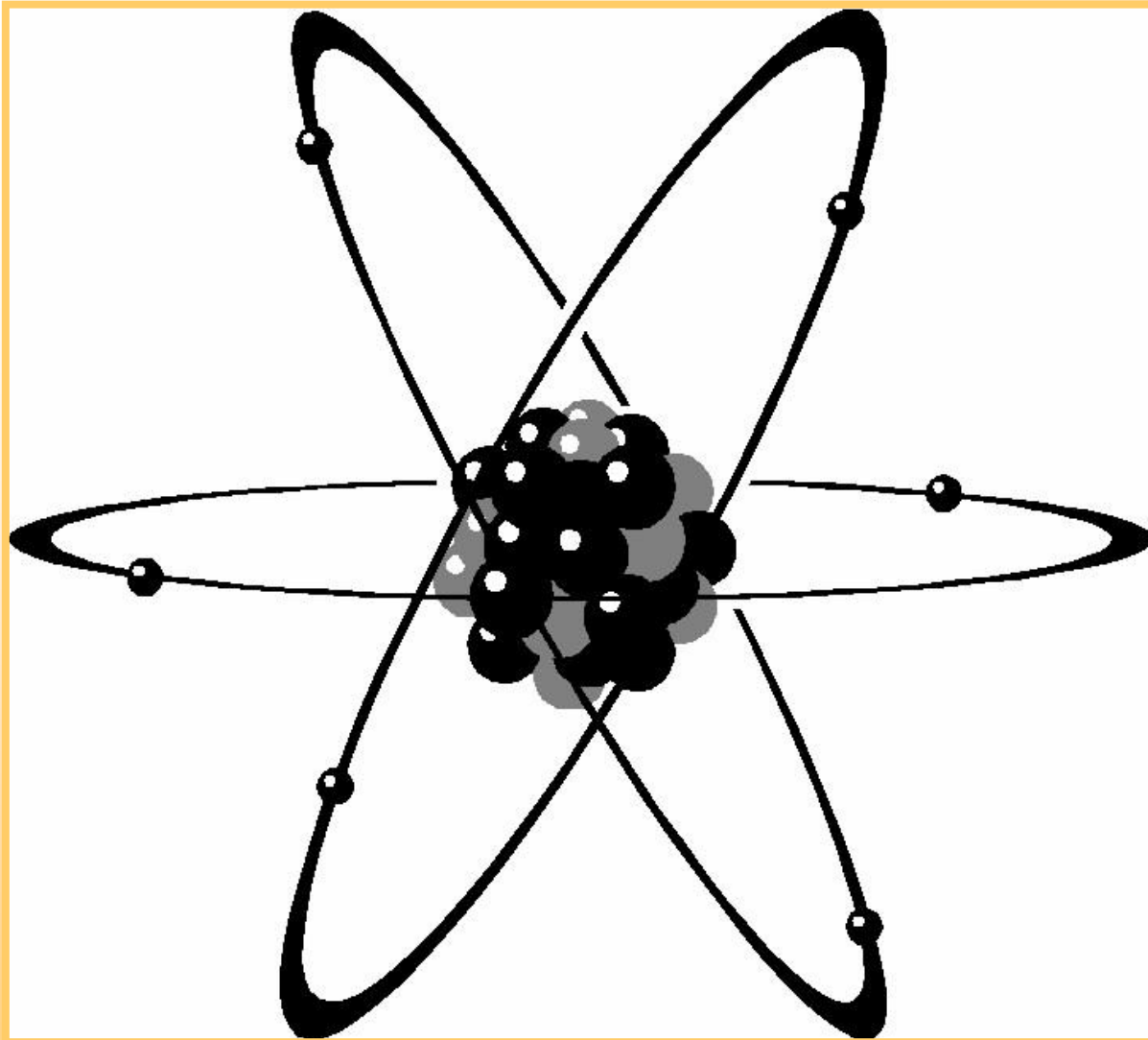

# Electrons Changing Orbitals

## RADIATION FROM ELECTRONS WITHIN ATOMS

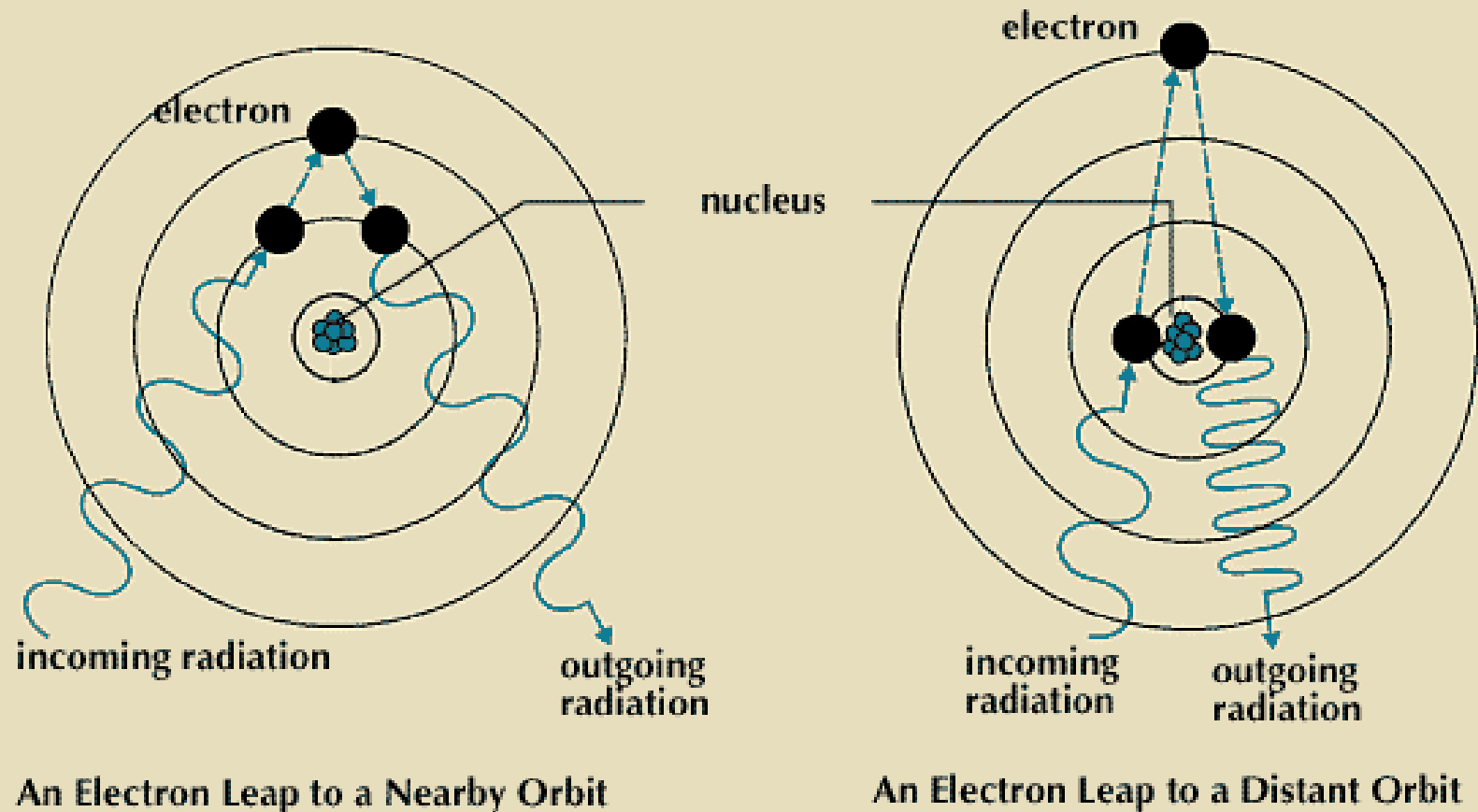

# Henry Moseley

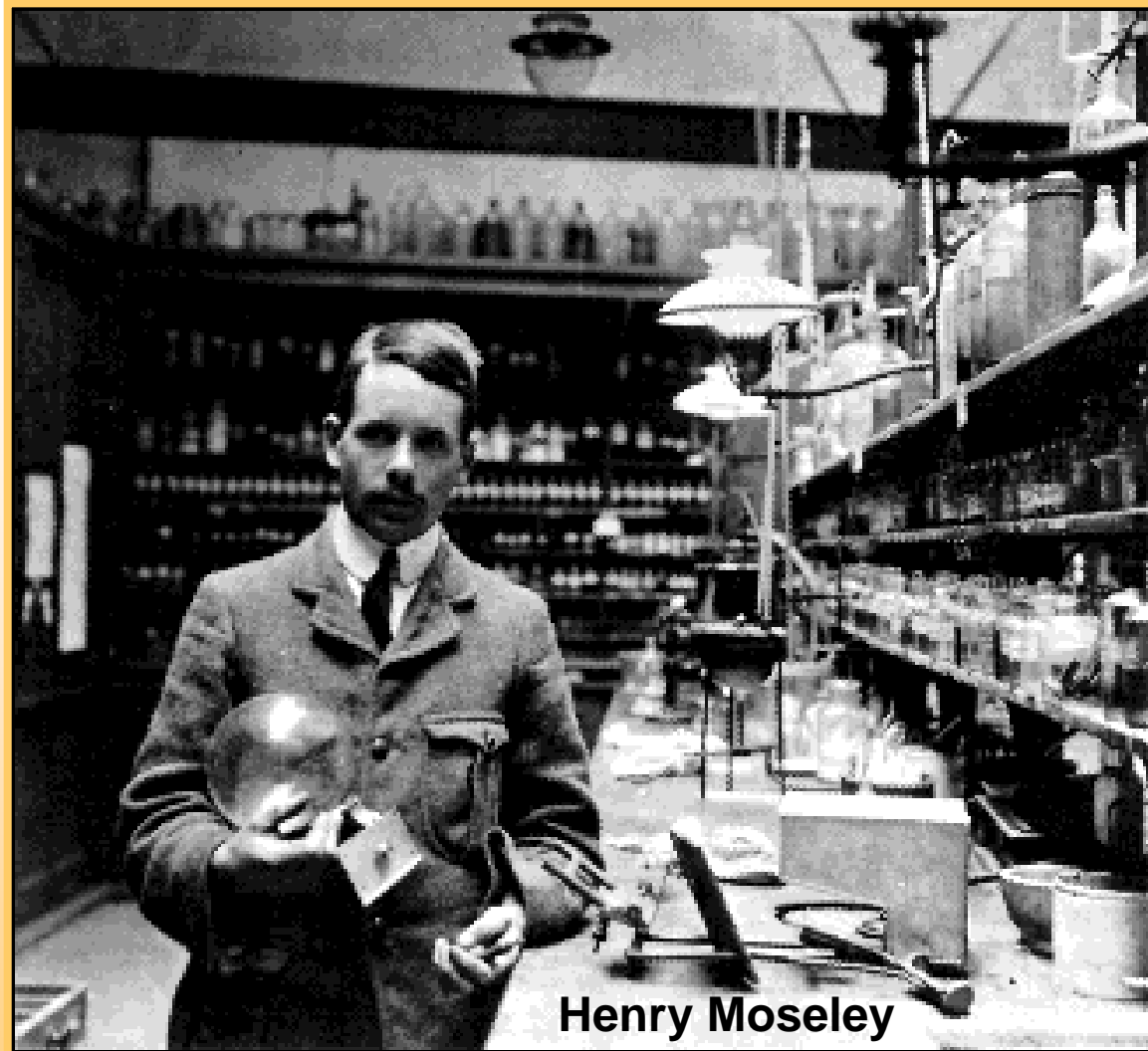

Henry Moseley

# Arnold Sommerfeld



Arnold Sommerfeld

# Elliptical Electron Orbitals

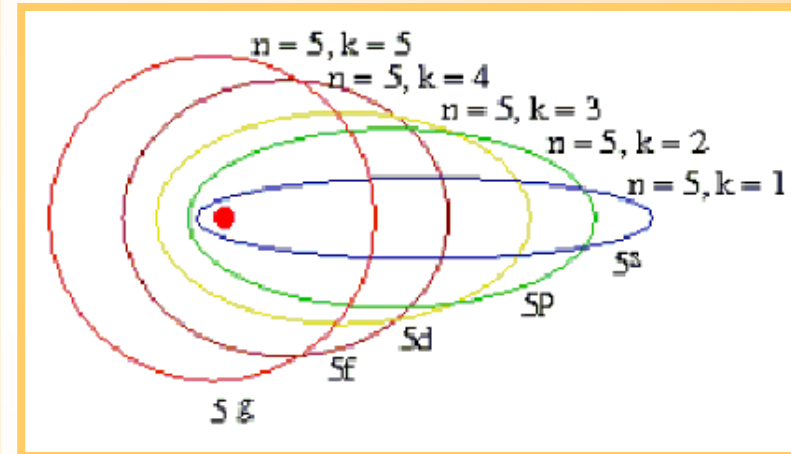
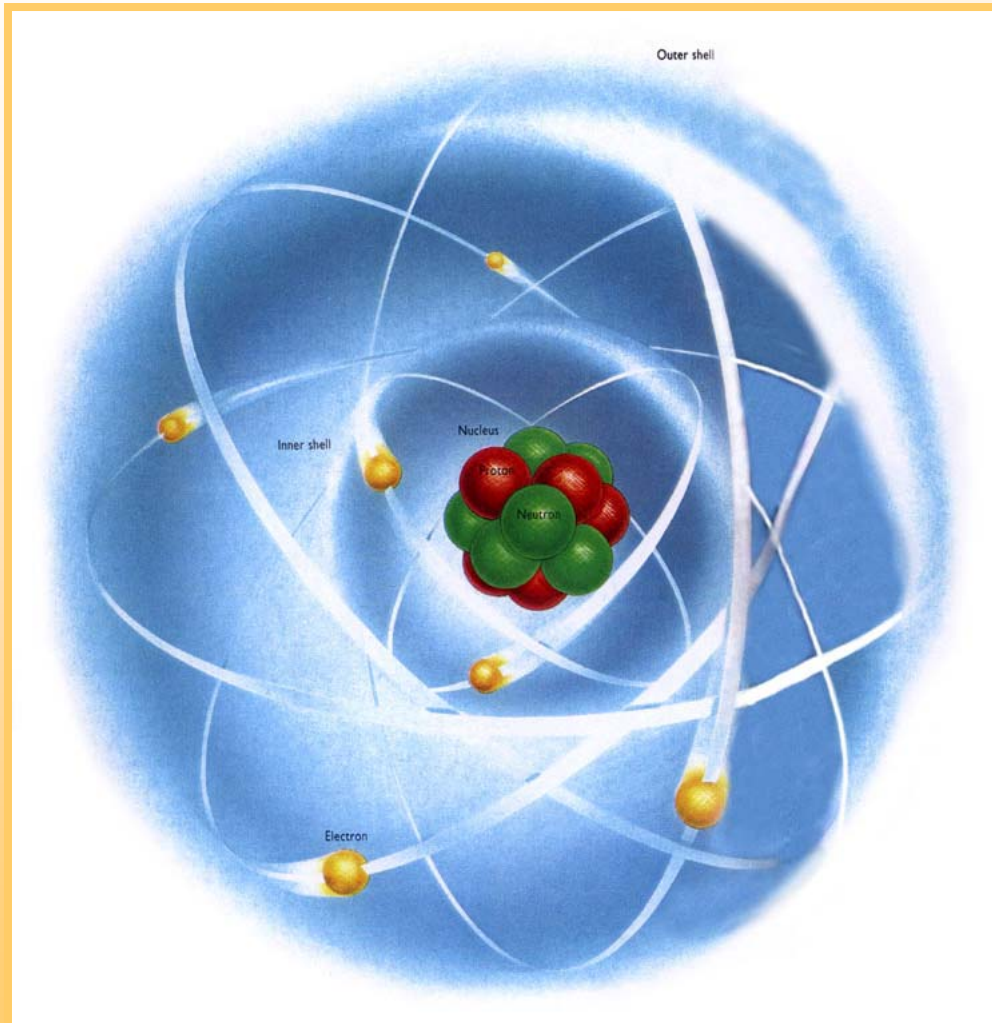

# Structure of the Atomic Nucleus

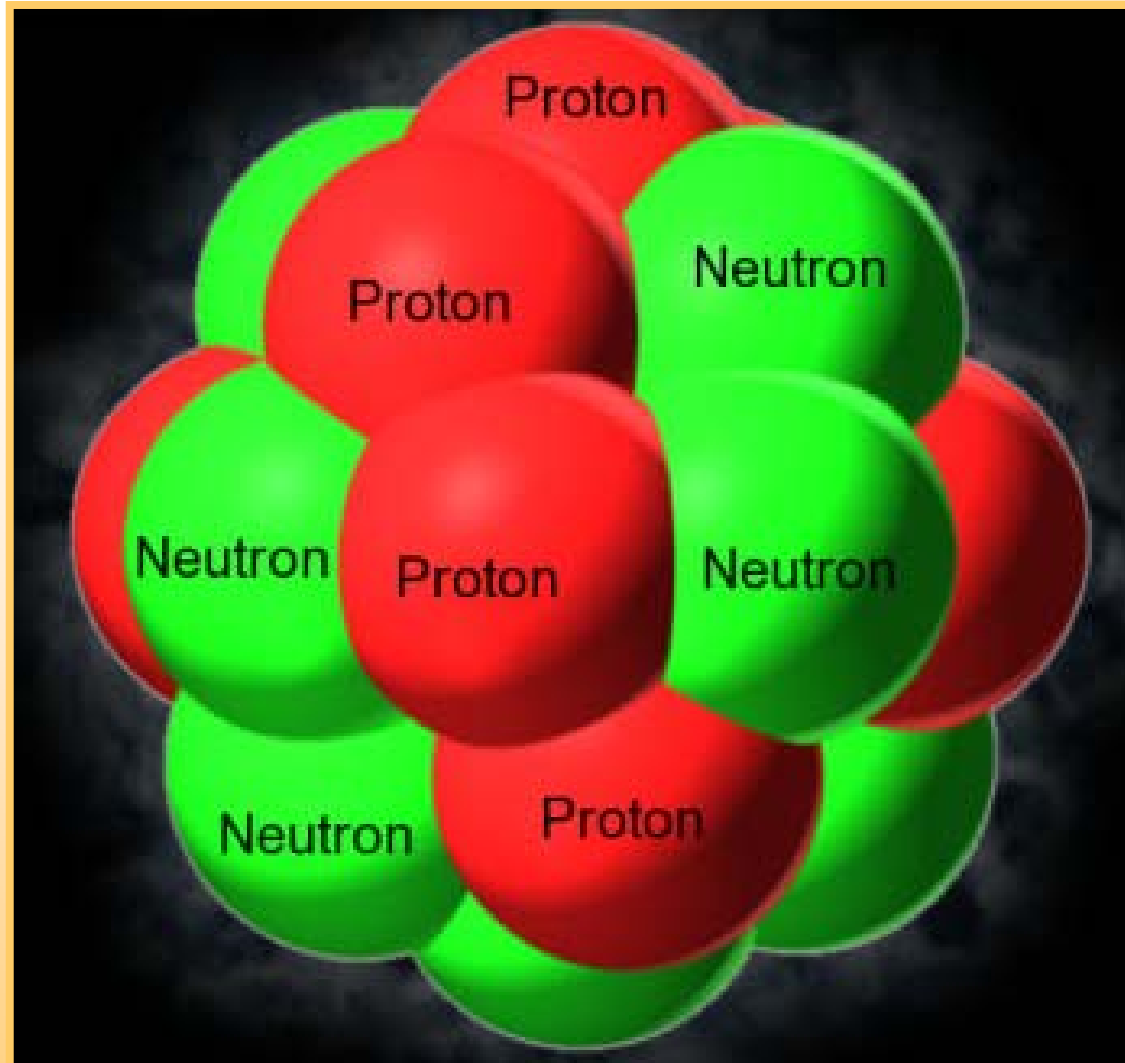

# Isotopes of Carbon

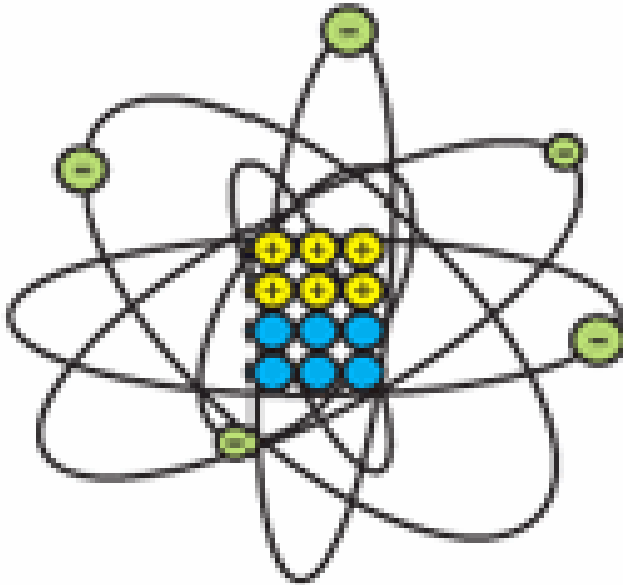

C-12 Stable

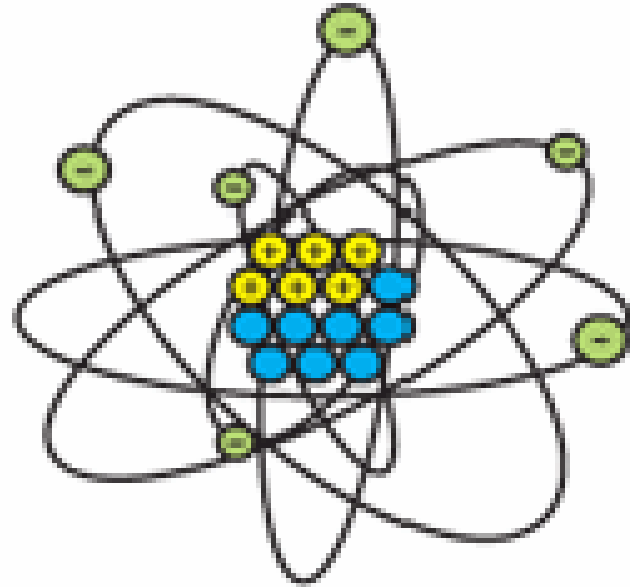

C-14 Unstable

# Helium Atom

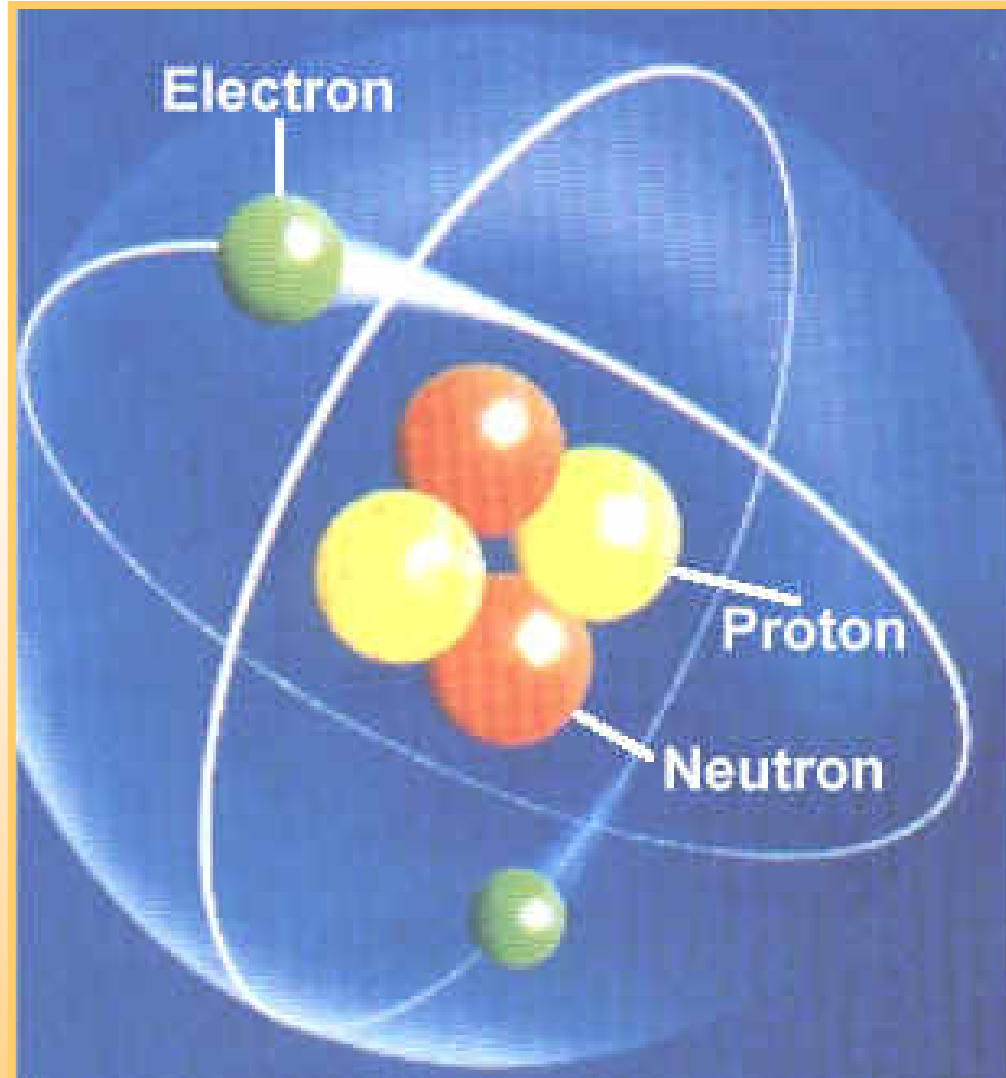

# The Photoelectric Effect

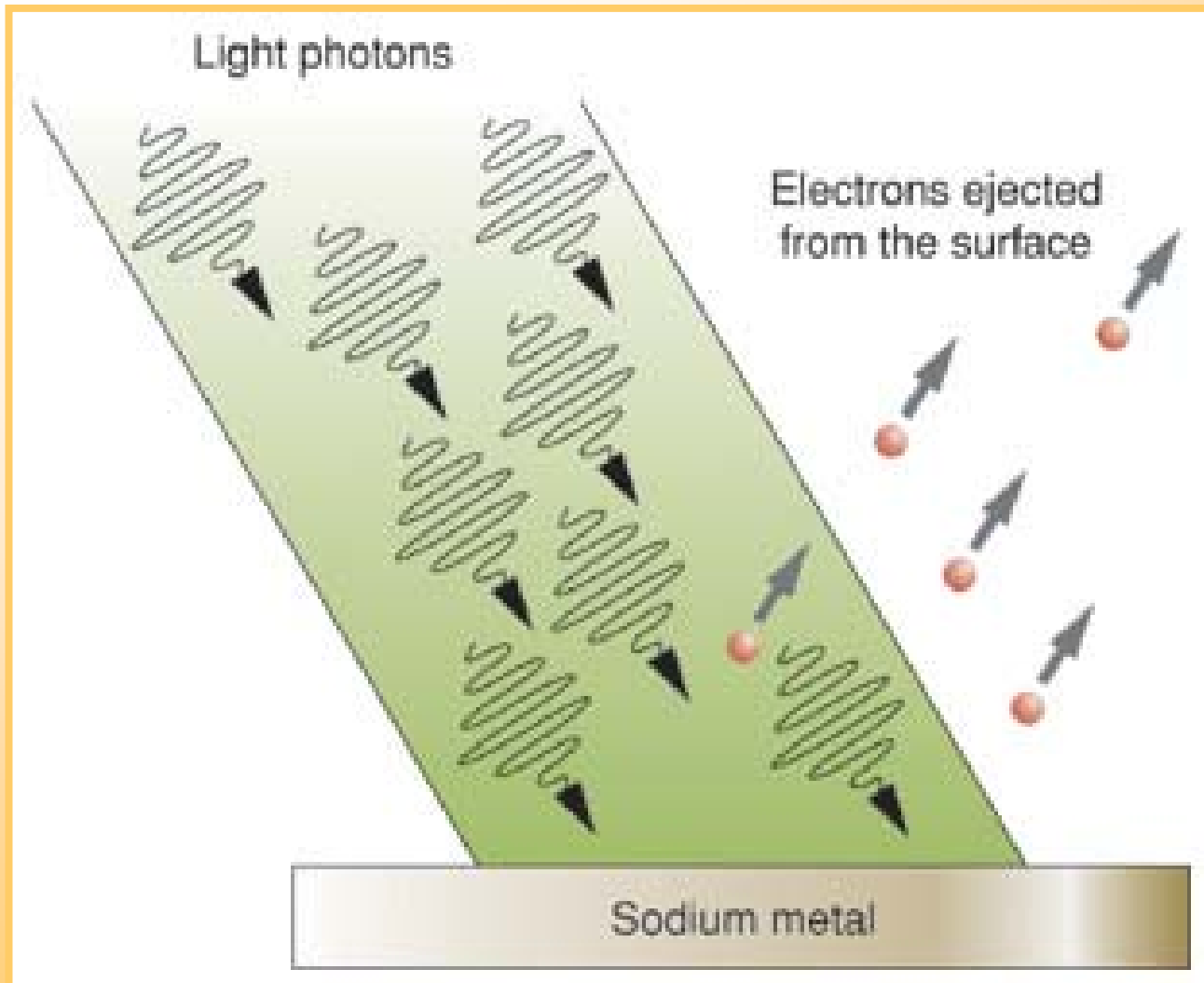

# Arthur Compton

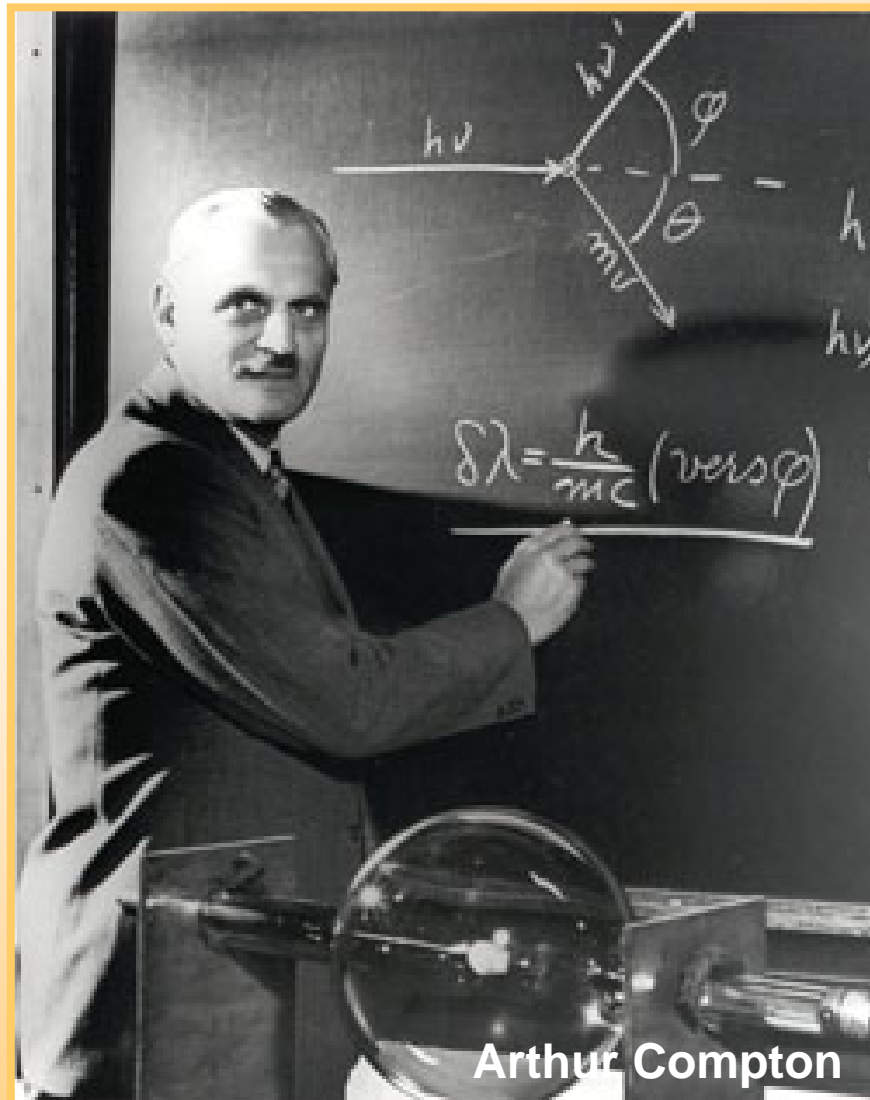

Arthur Compton

# Louis de Broglie



Louis de Broglie

# De Broglie's Wave Orbitals

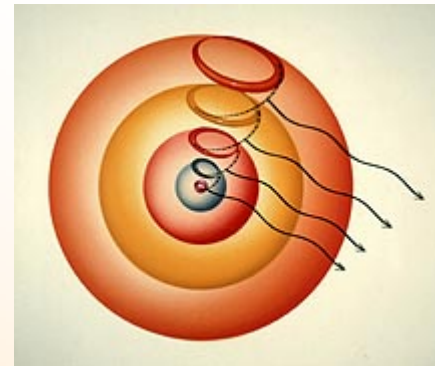
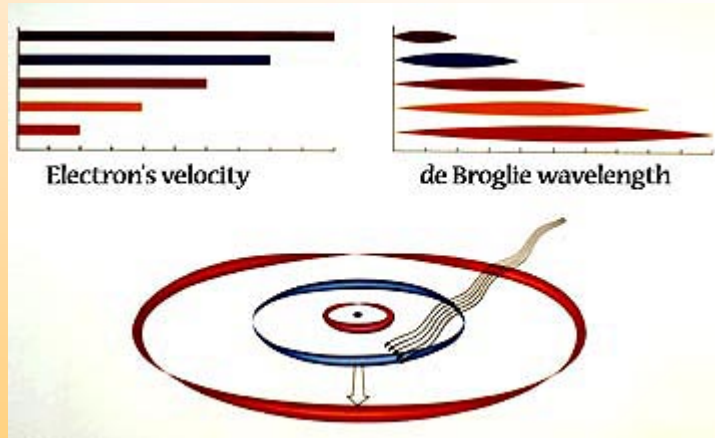
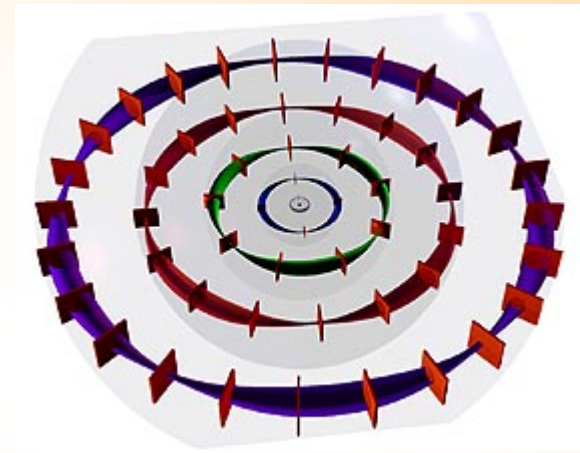
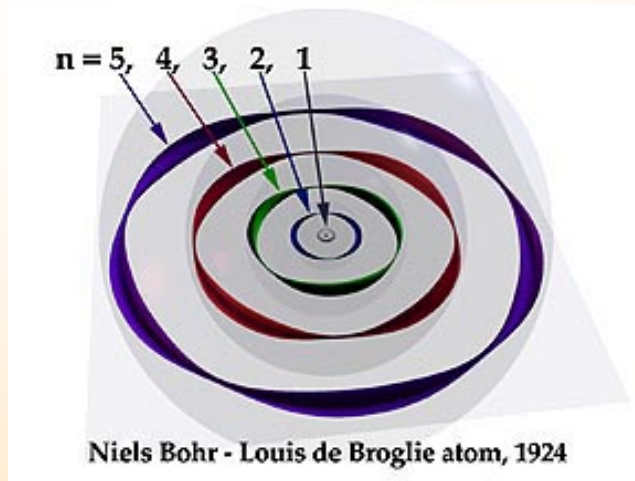

# Wolfgang Pauli



Wolfgang Pauli

# Max Born

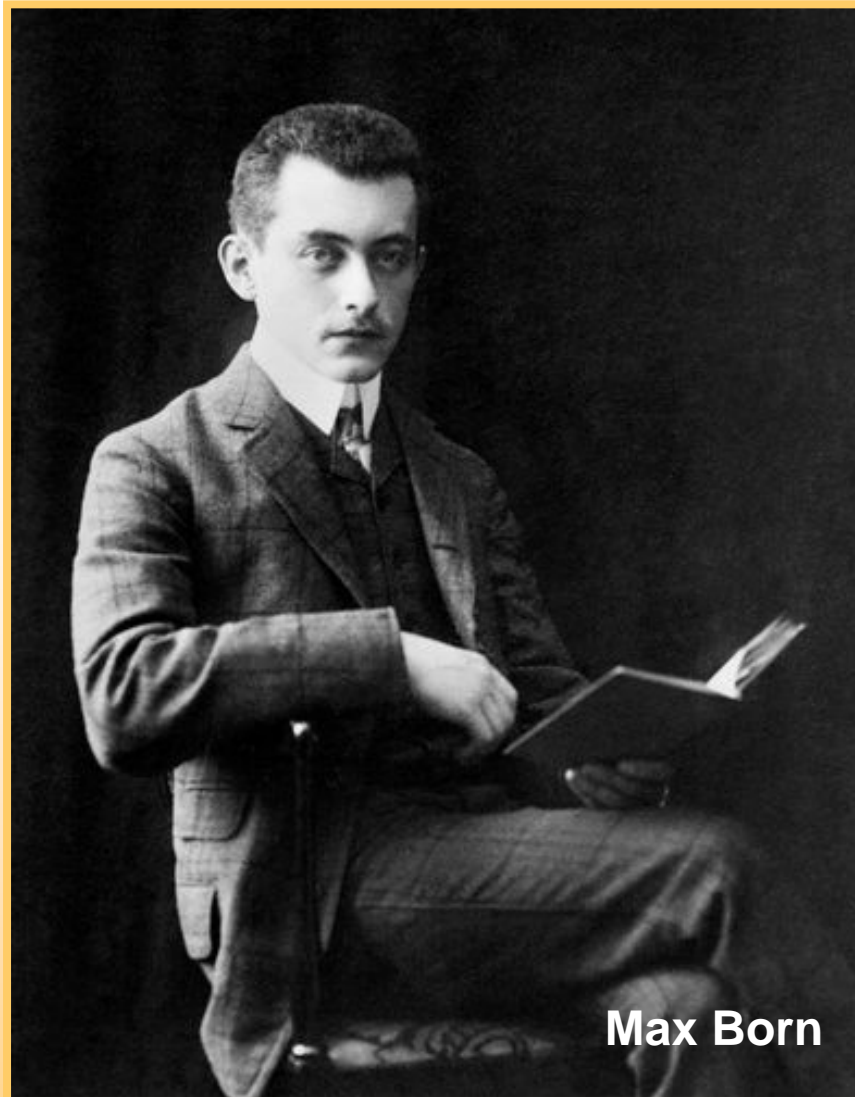

Max Born

# Tunnel Diode

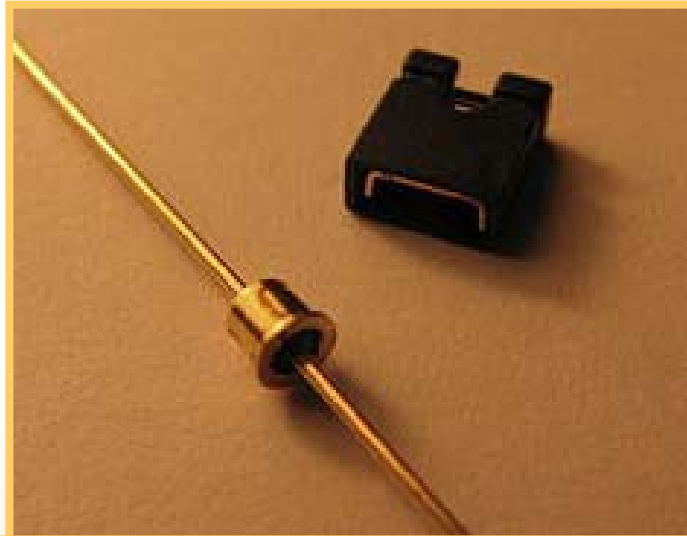

TUNNEL DIODE OSCILLATOR CIRCUIT

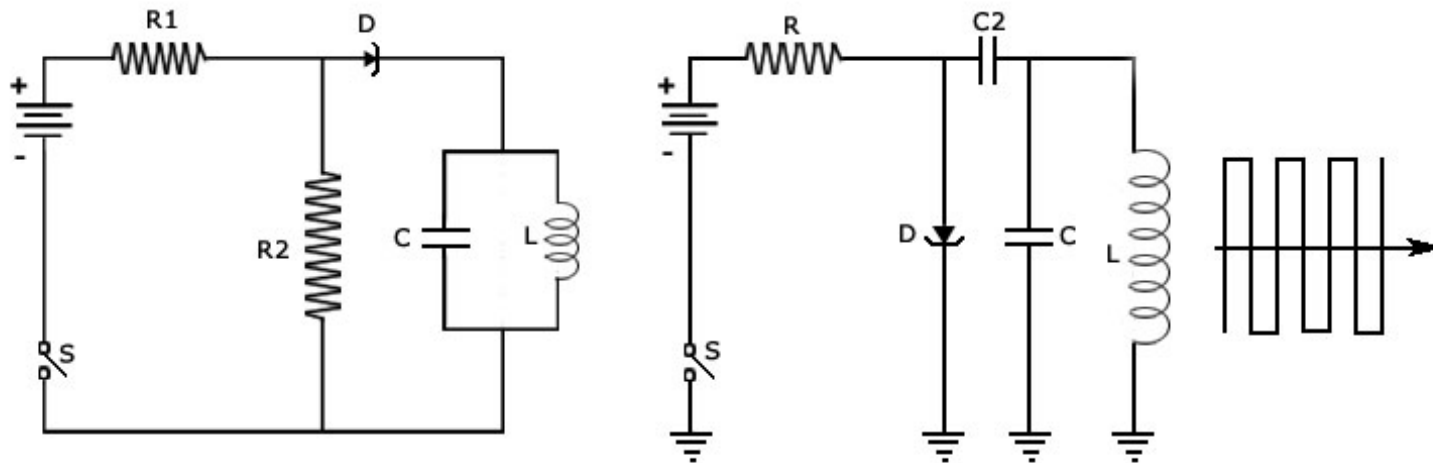

# Werner Heisenberg

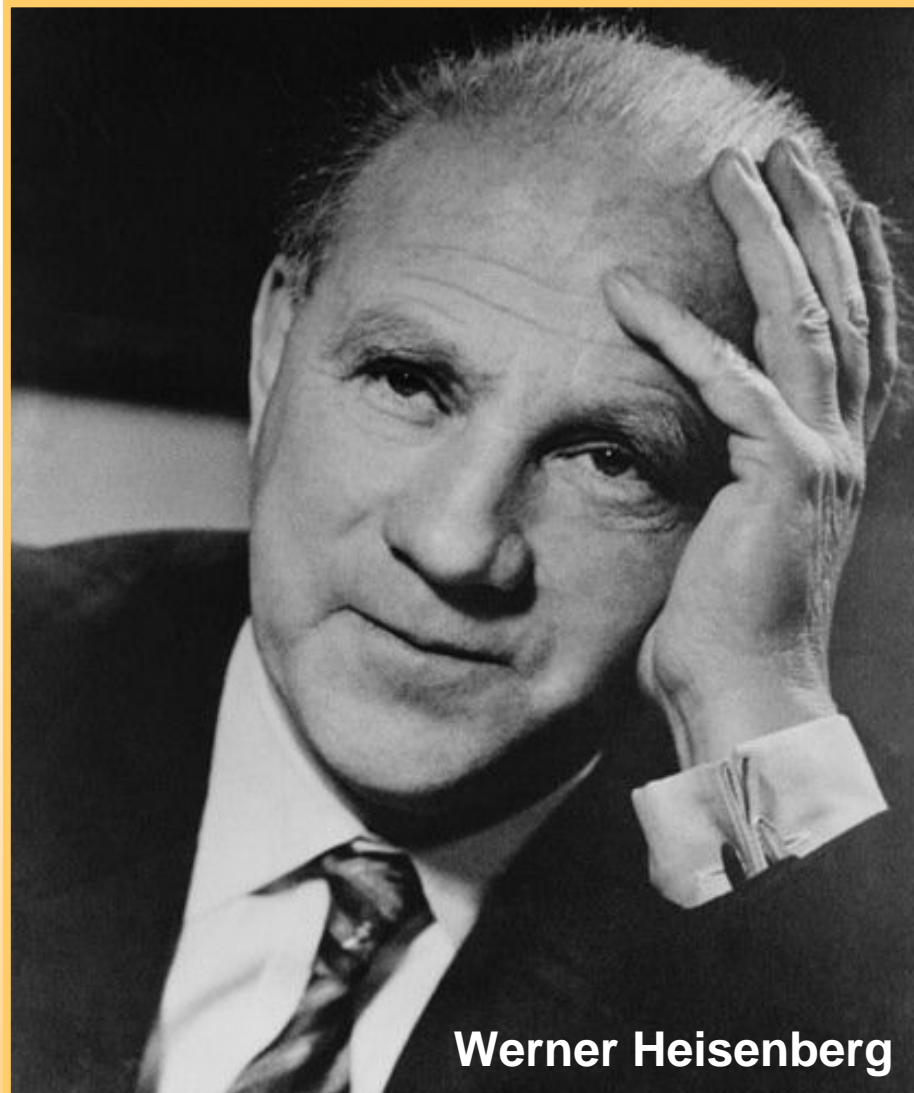

Werner Heisenberg

# Two Slit Experiment With Light

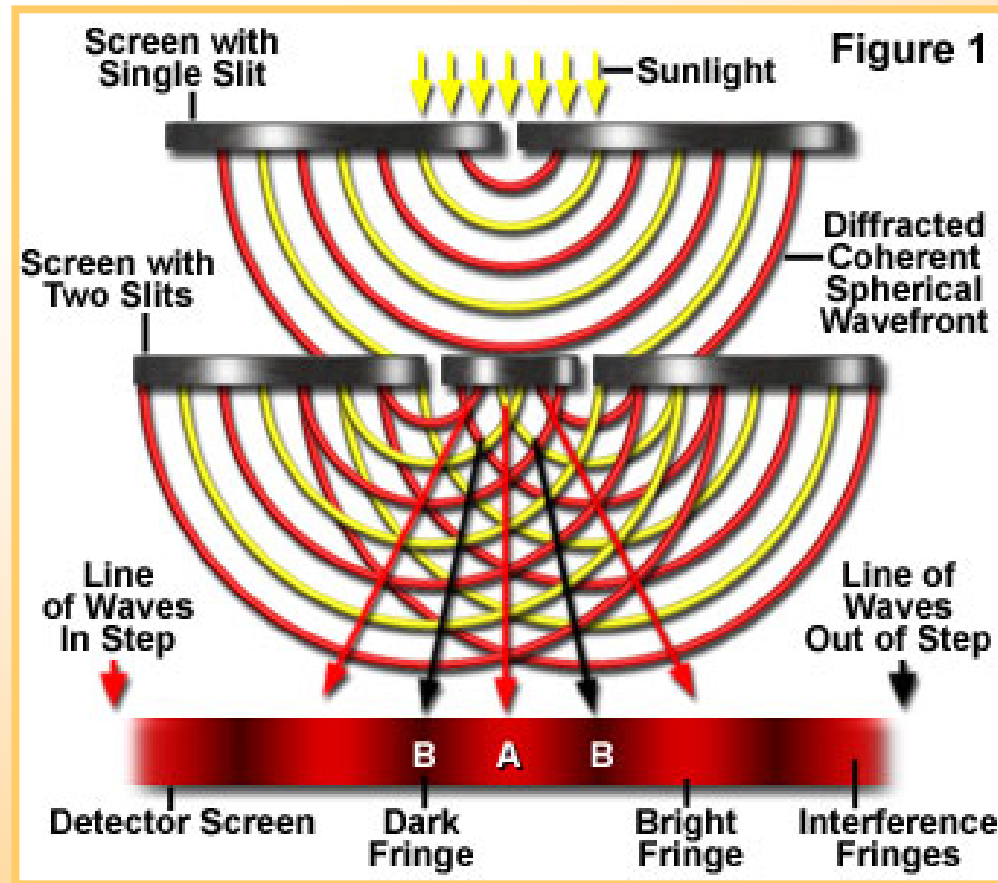

# Two Slit Experiment With Electrons

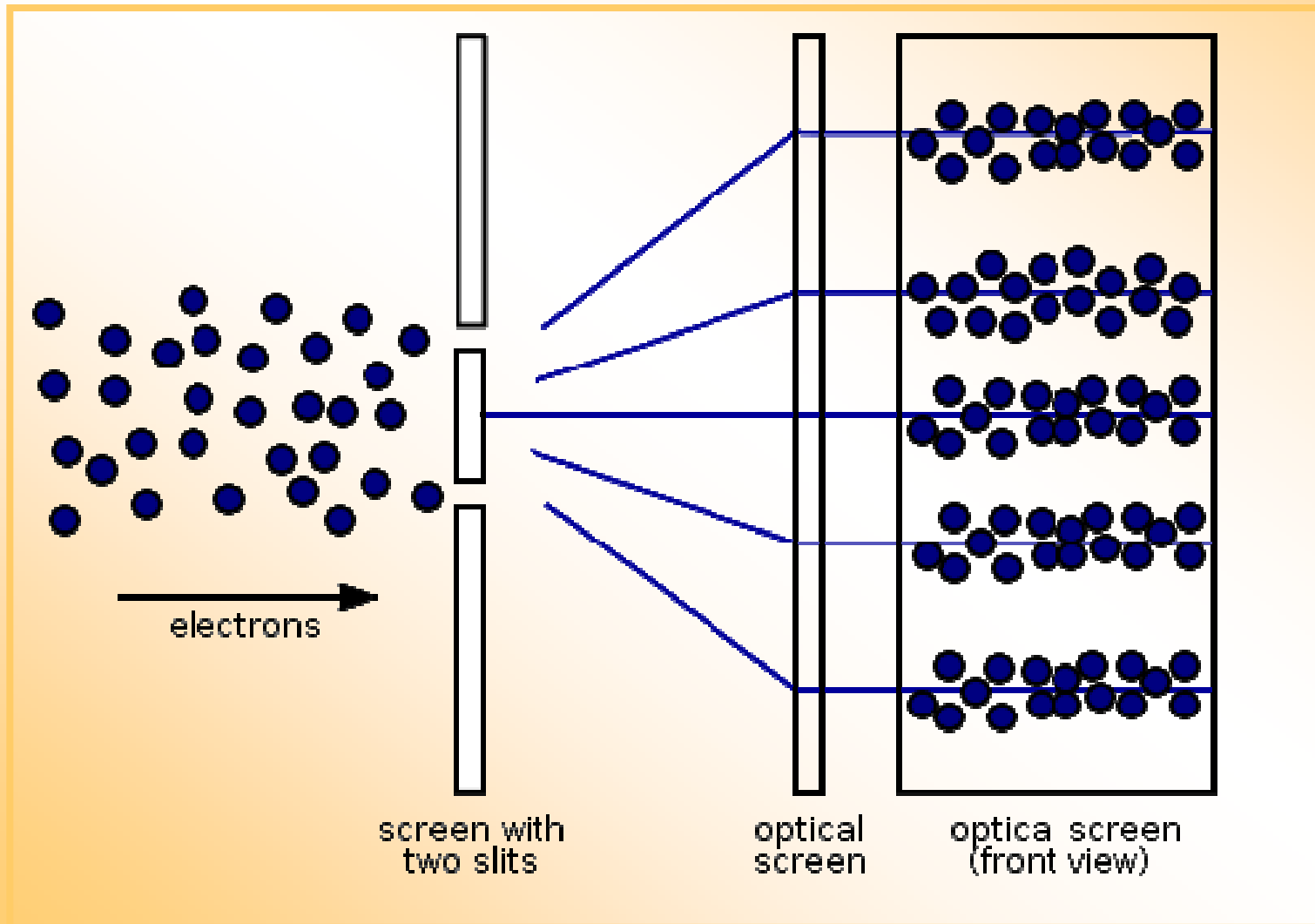

# Two Slit With Detector

Detector

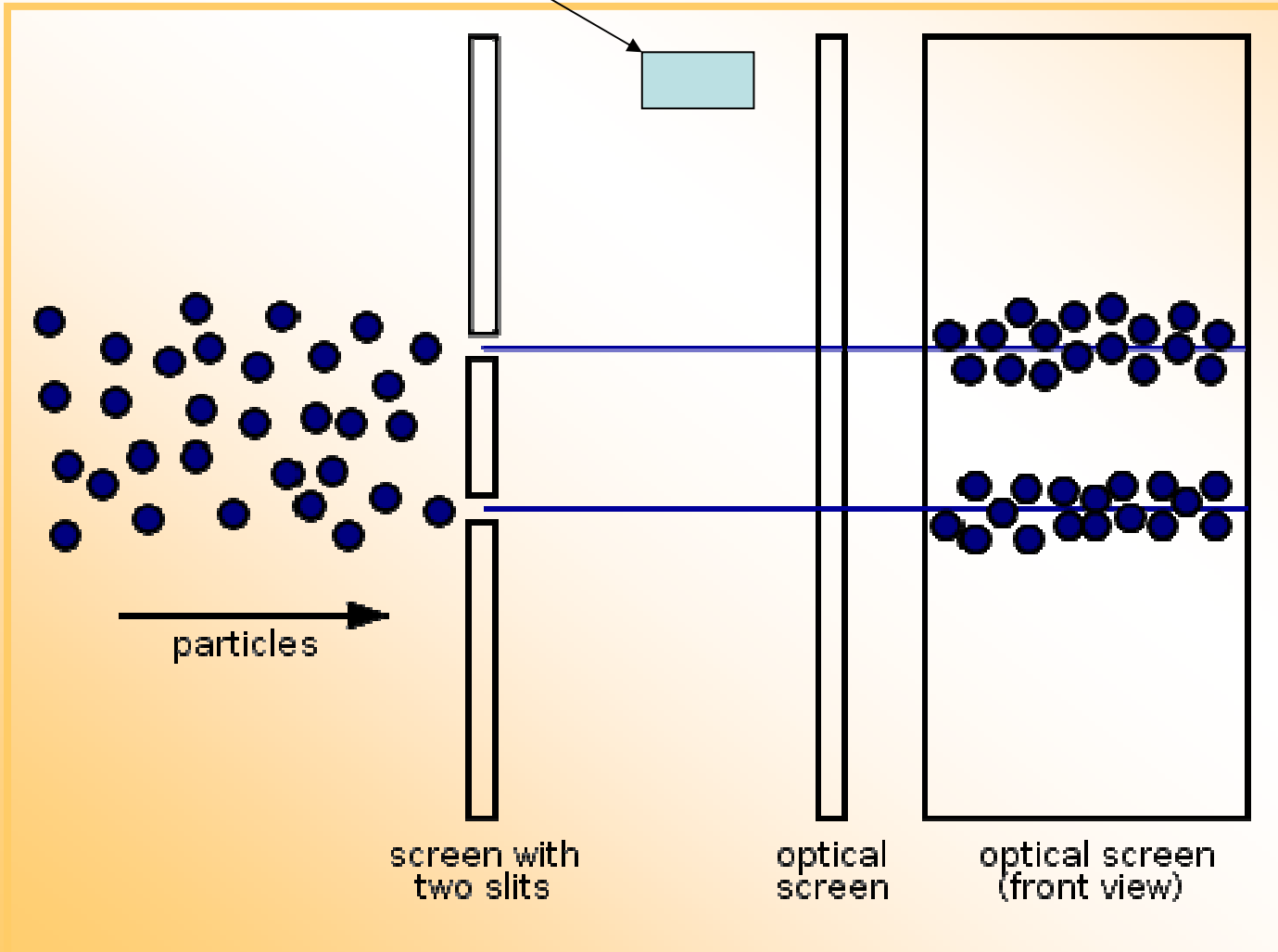

# Paul Dirac



Paul Dirac

# Feynman and Schwinger

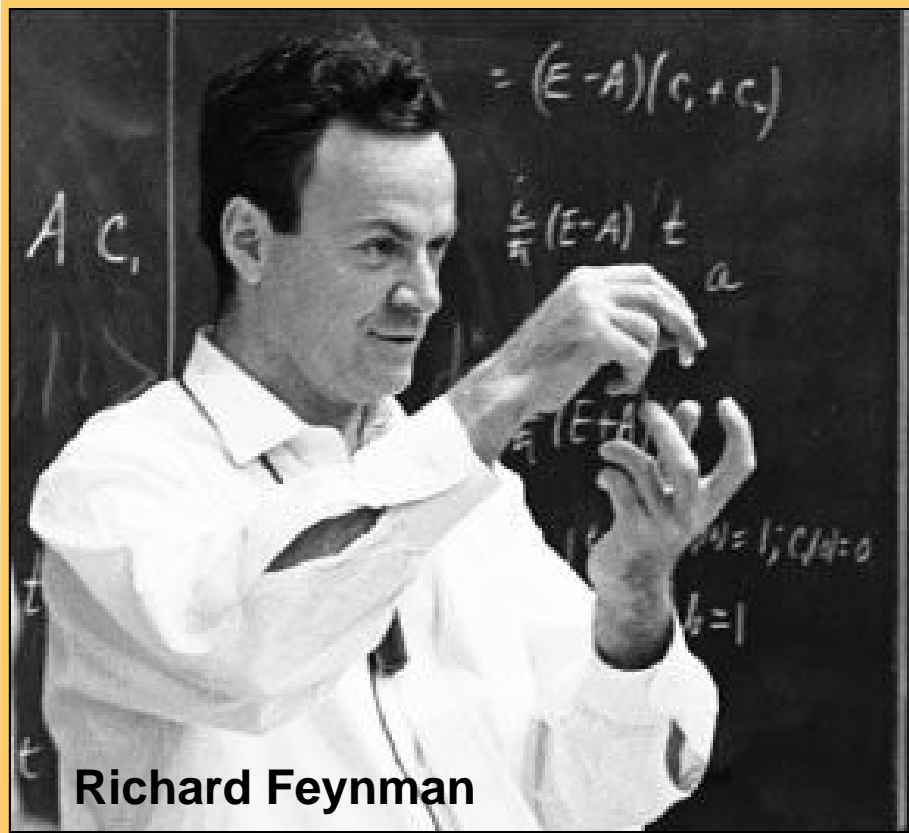

**Richard Feynman**



**Julian Schwinger**

# Salam, Glashow and Weinberg

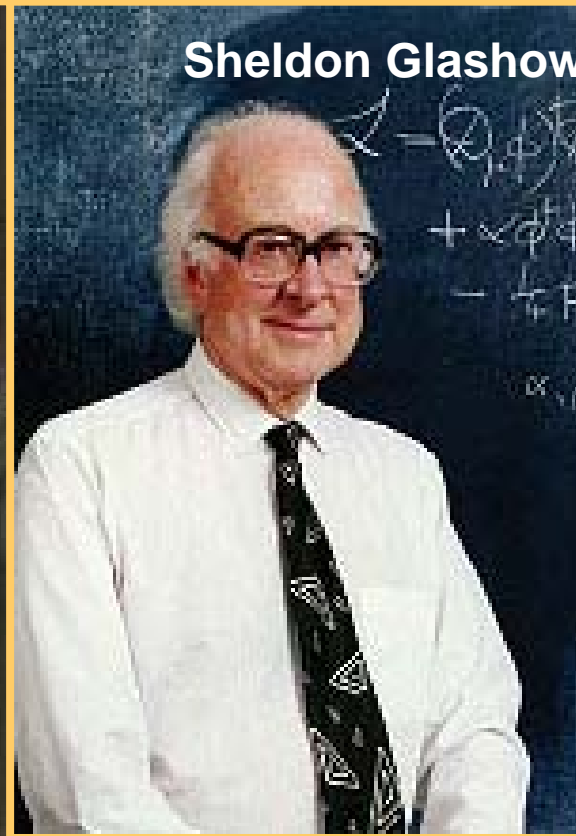
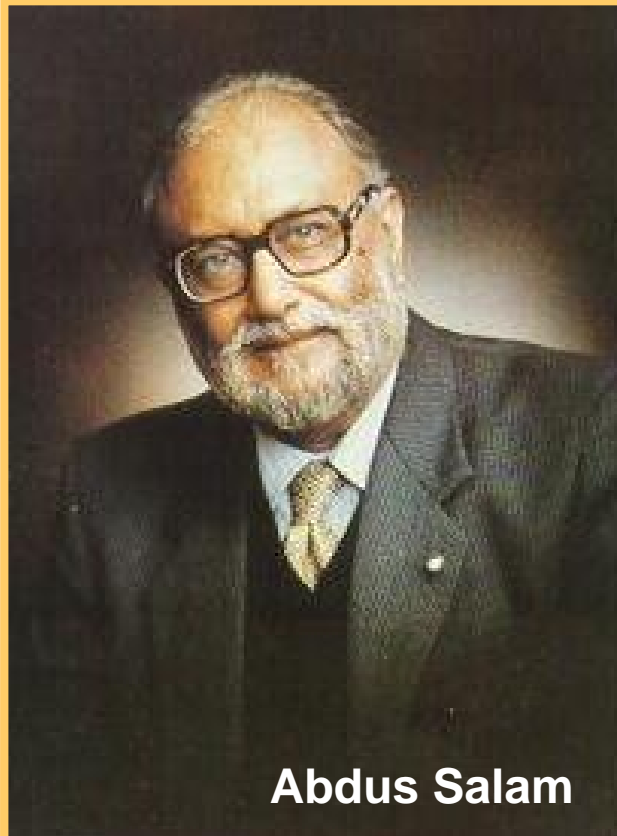

# Gell-Mann and Zweig

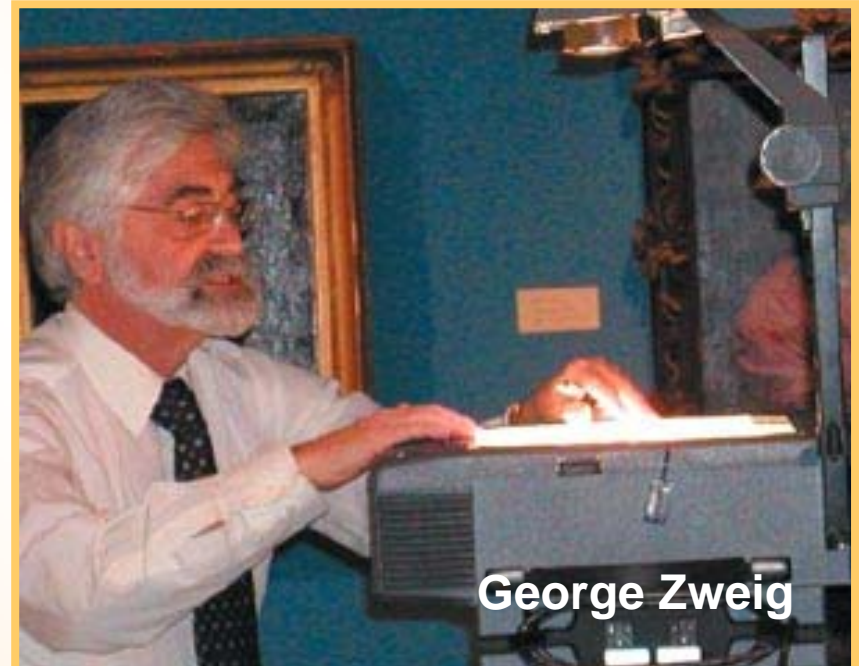

# The Fundamental Particles

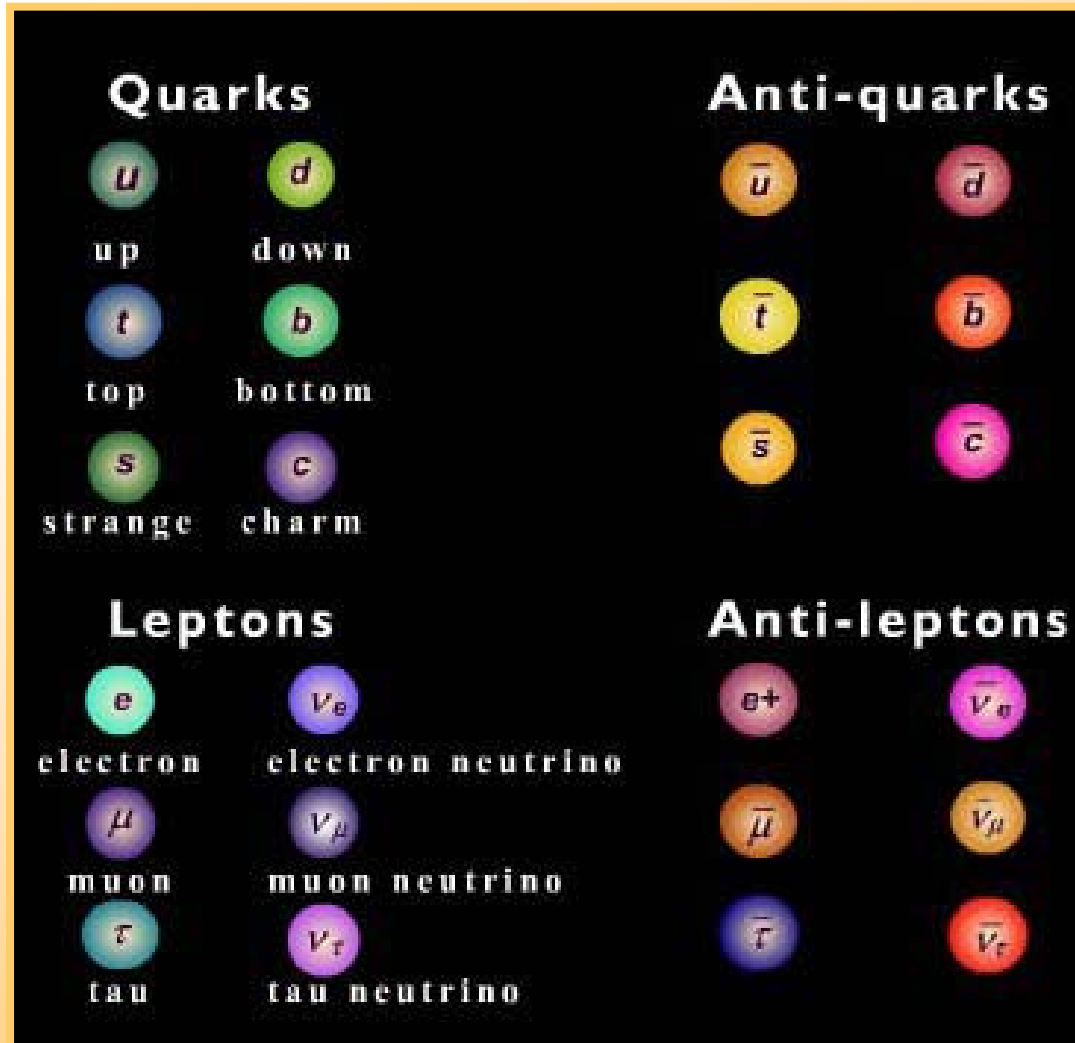

# Hadrons

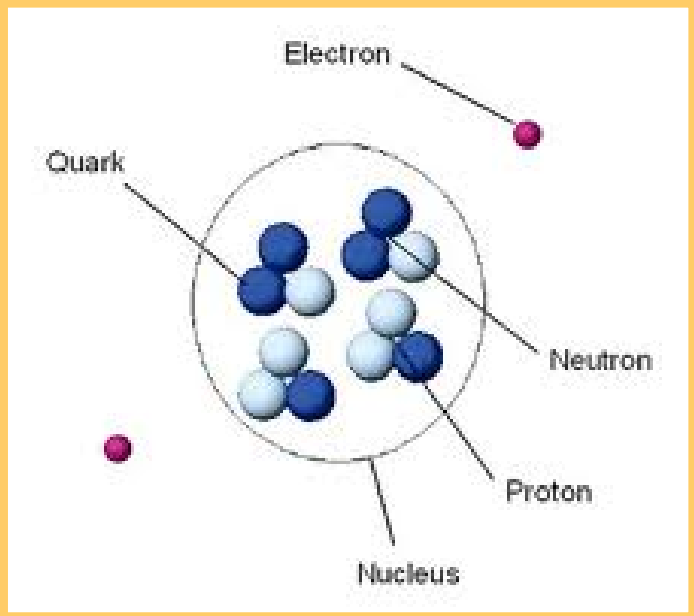
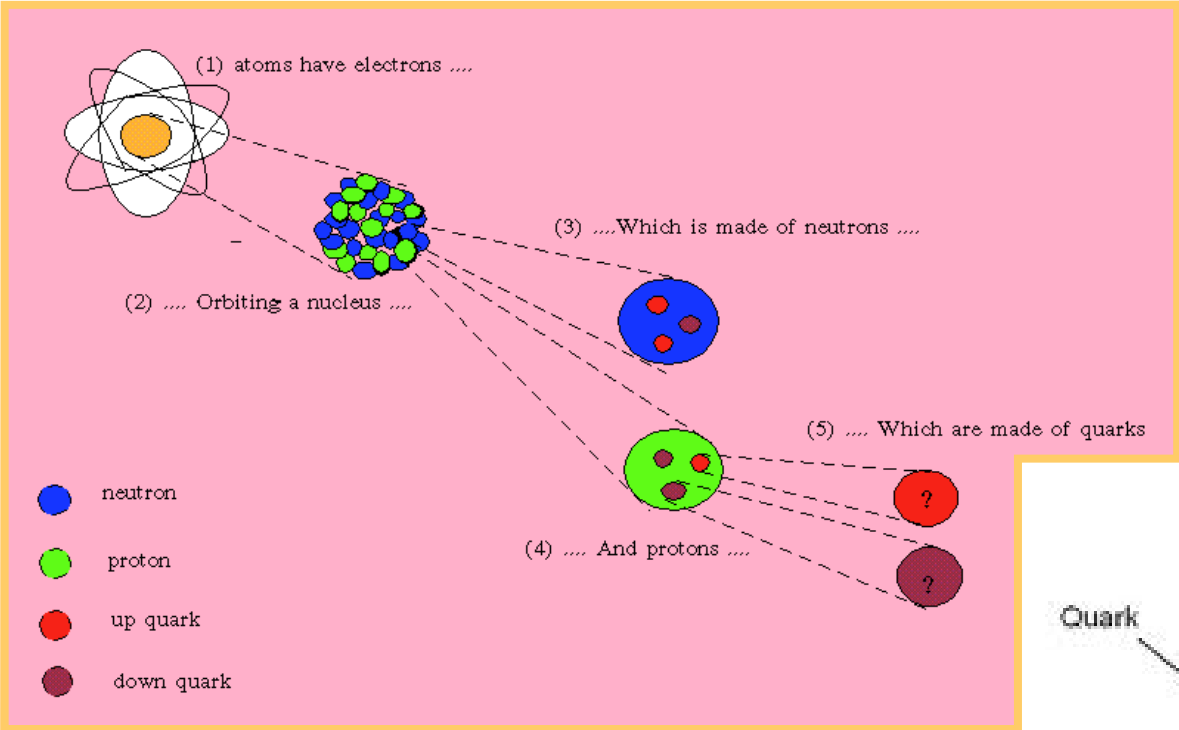

# Quark Structure of Hadrons

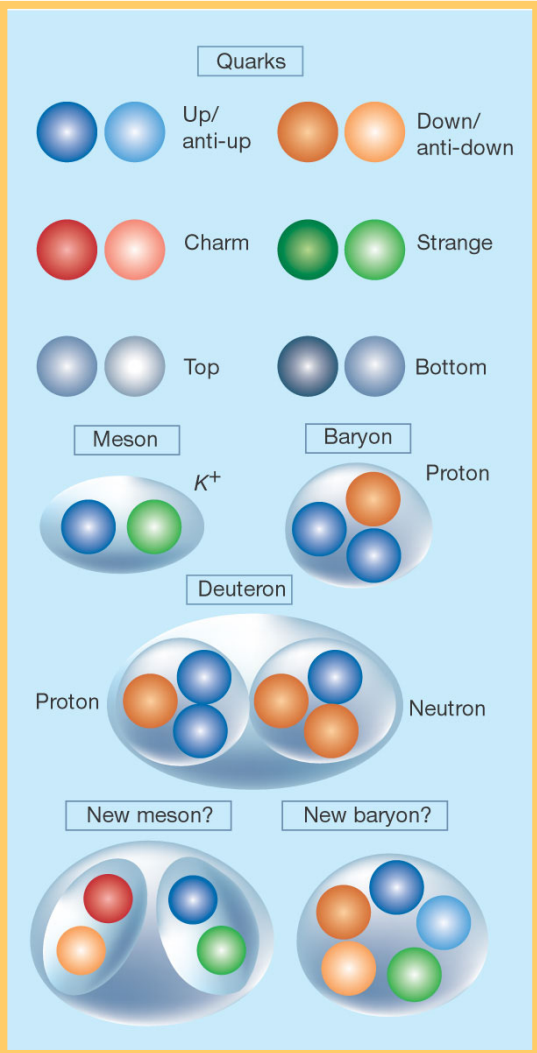

# Quark Structure of Hadrons

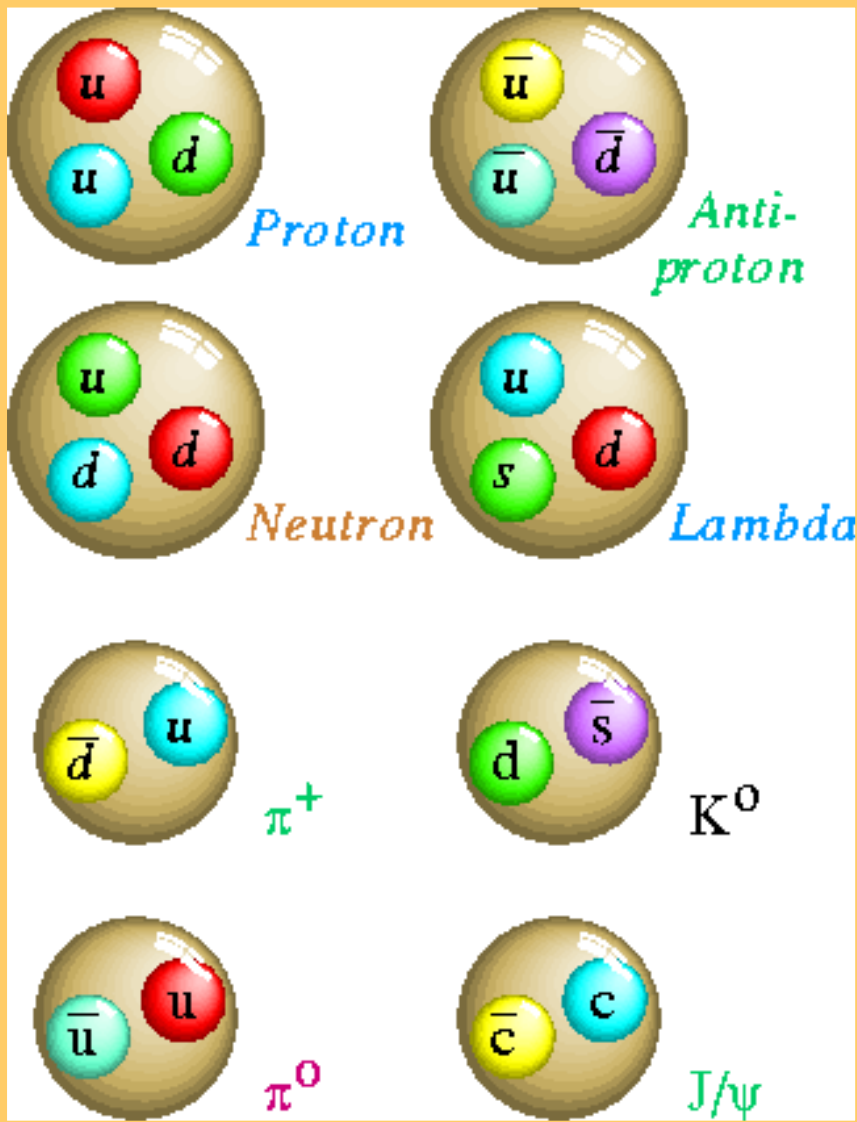

# Particle Traces in the LHC

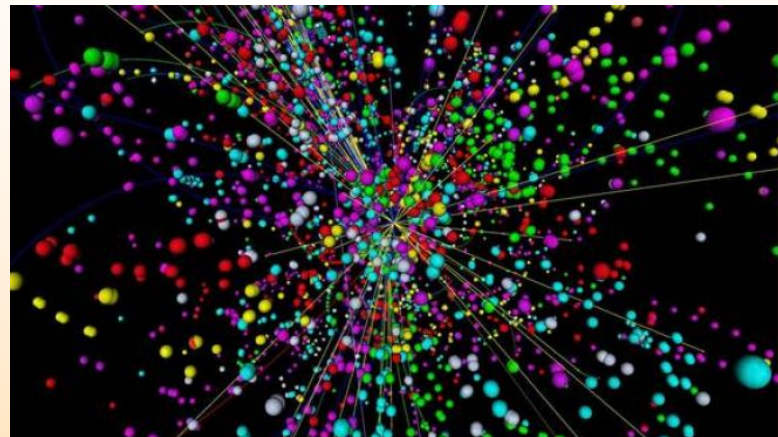
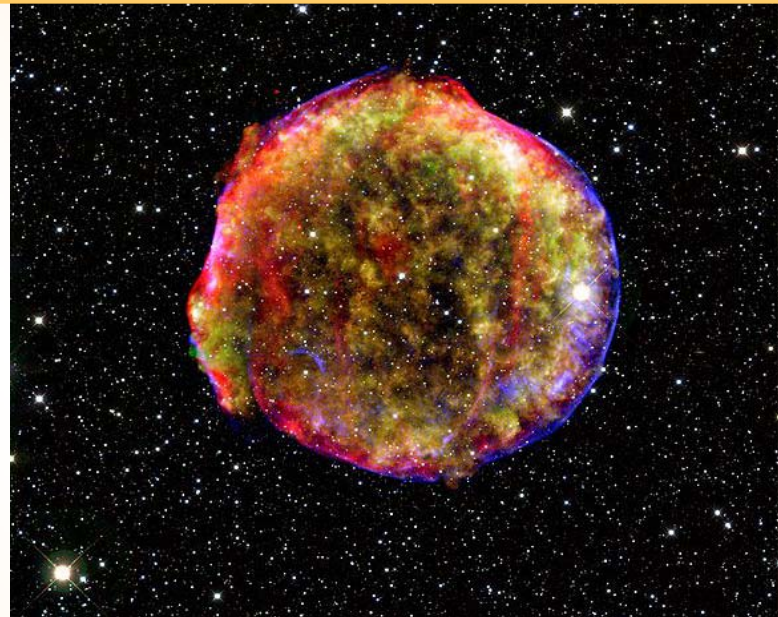
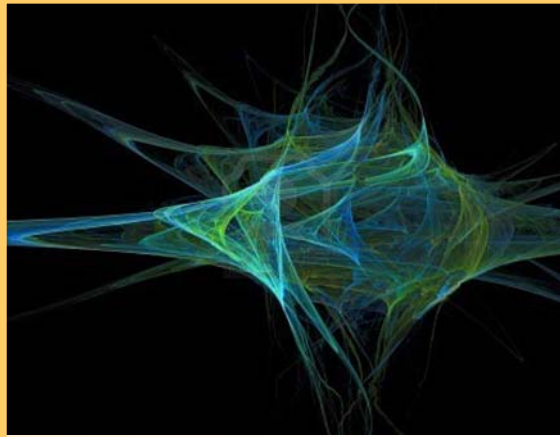

# The Sun

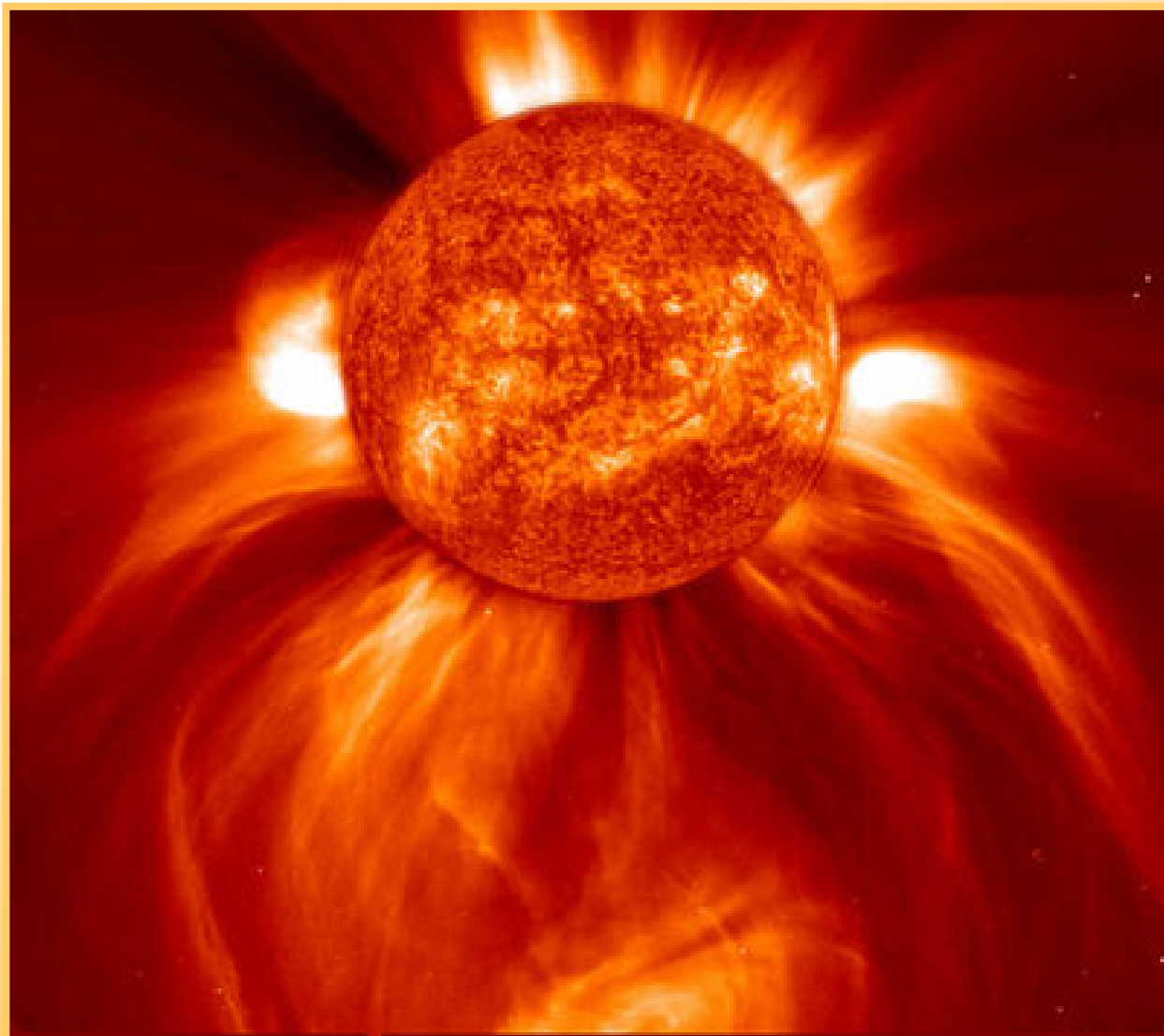

# How the Sun Shines

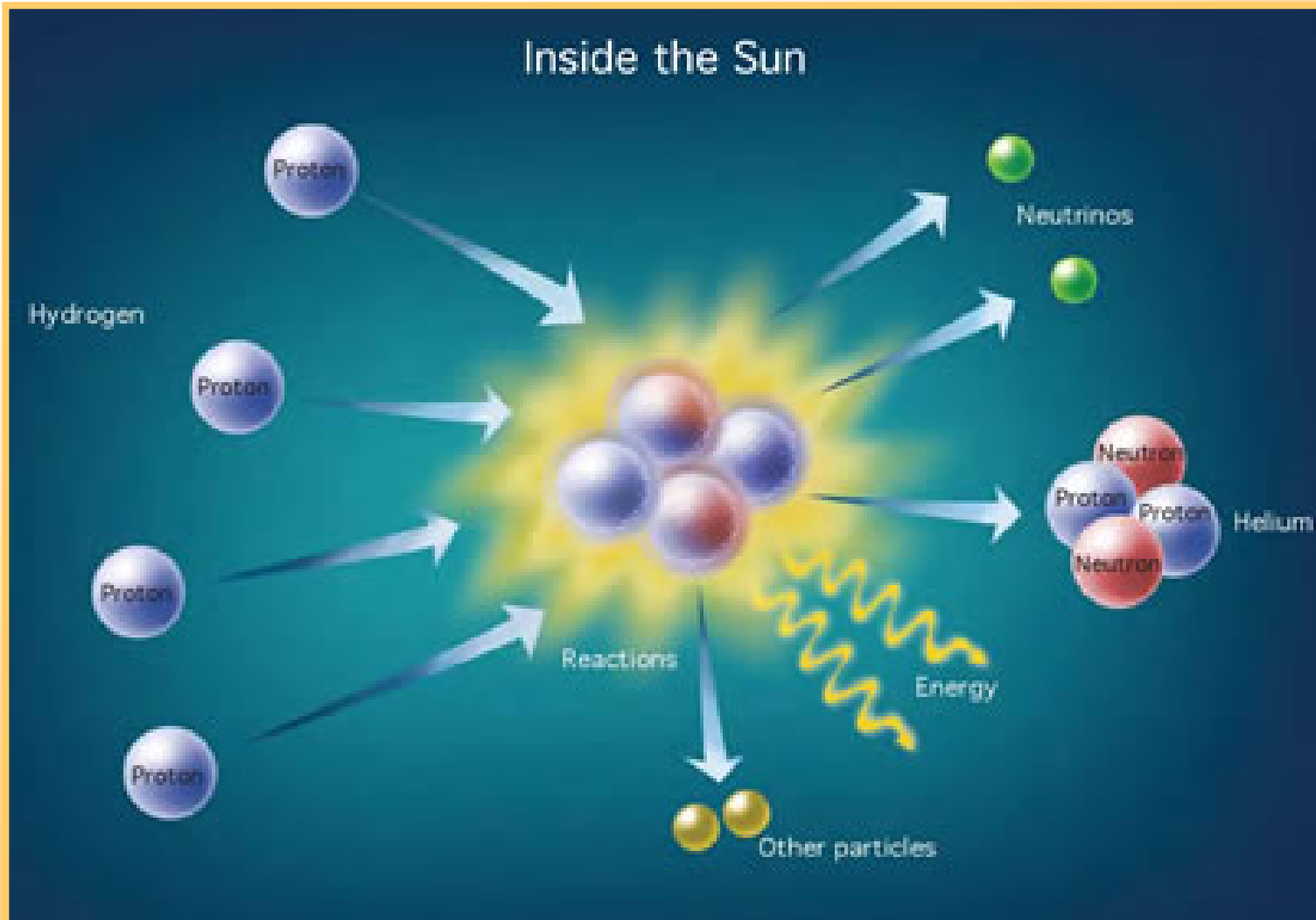

# A Ball

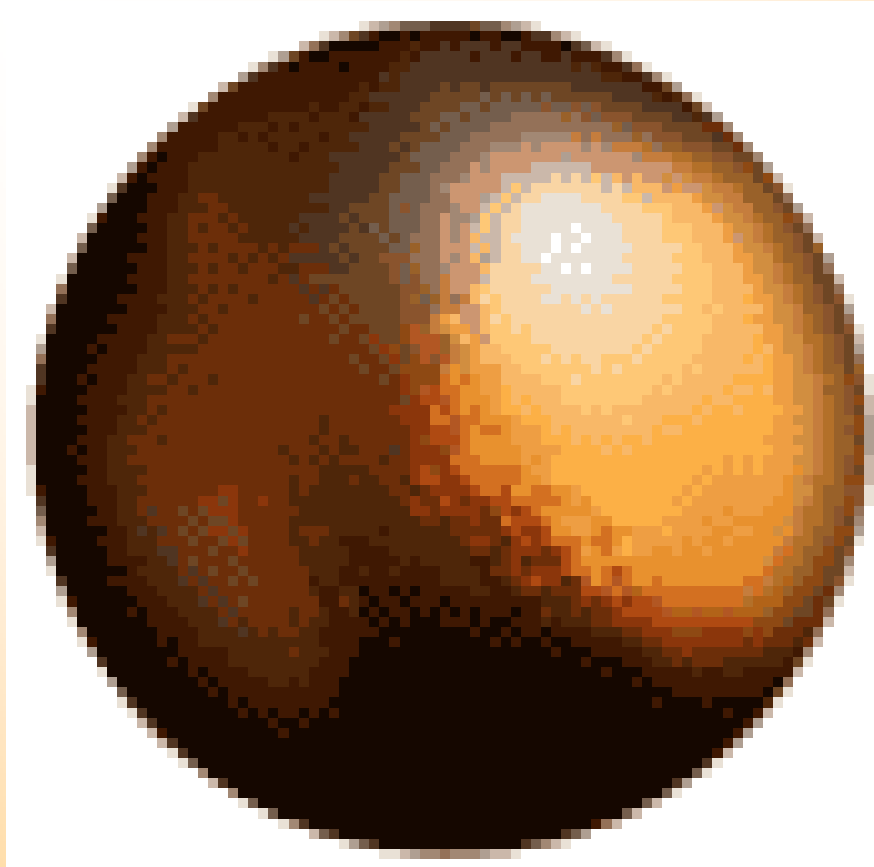

# Children in a Nursery



# Superconductivity

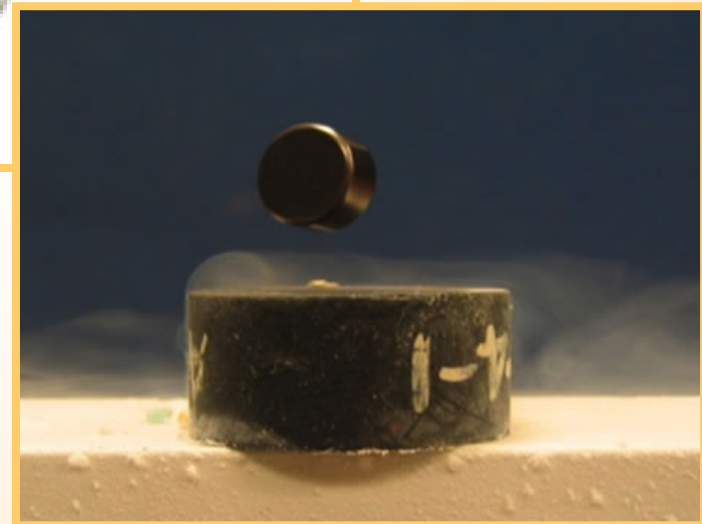
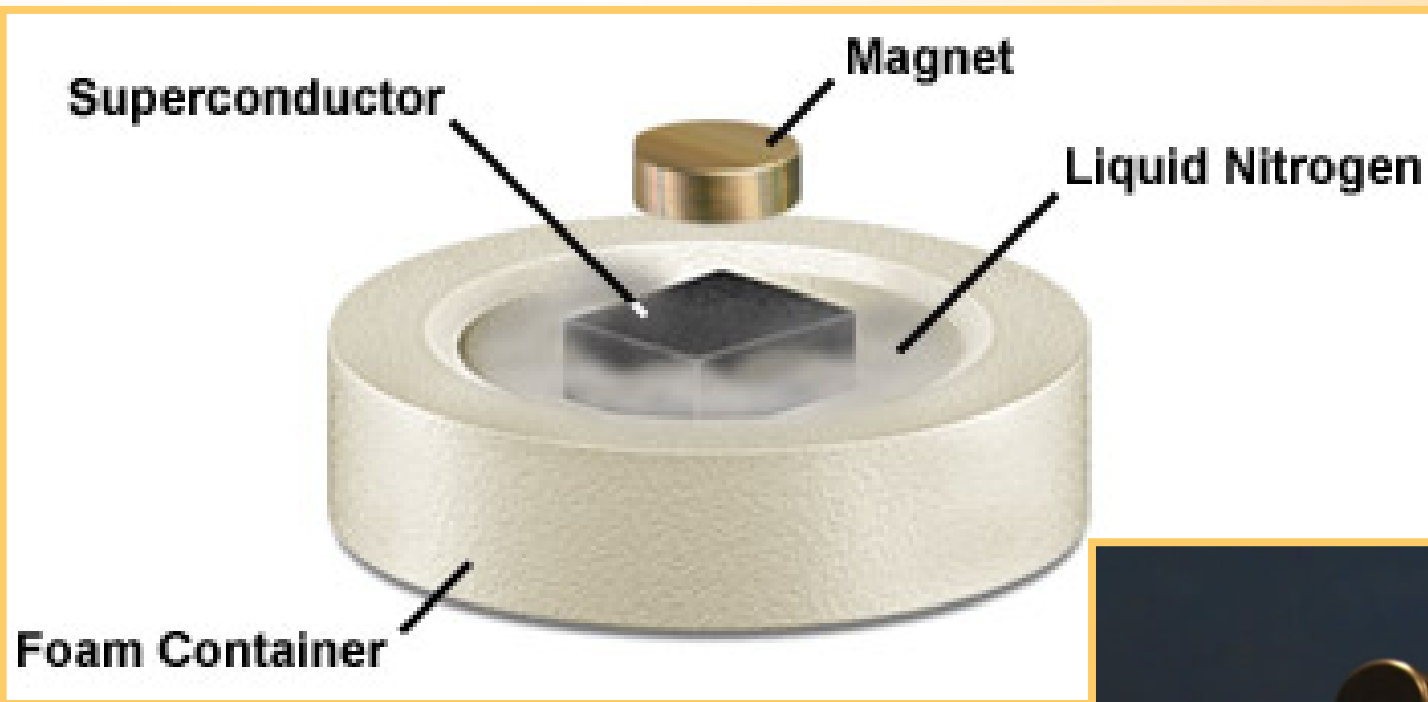

# The Earth



